

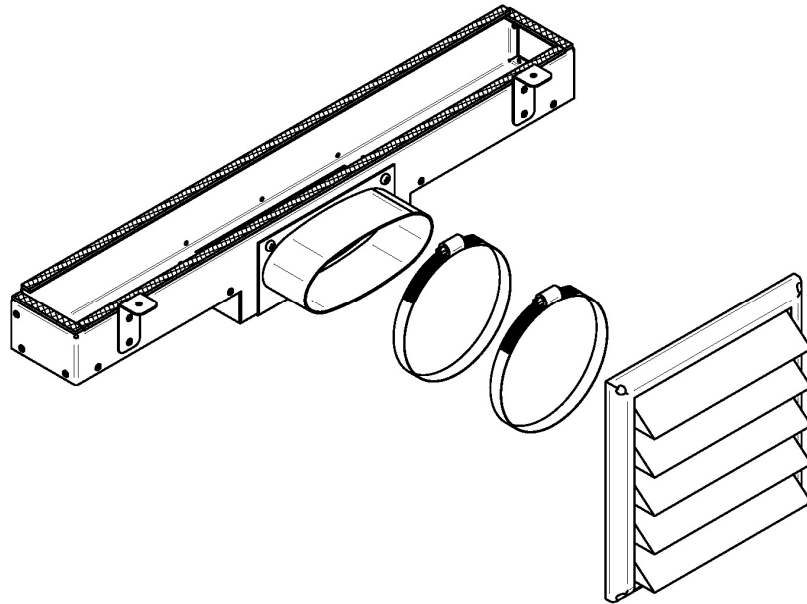

FRESH AIR INTAKE KIT
AC01337

INSTALLATION
INSTRUCTIONS



This manual is available for free download on the manufacturer's web site. It is a copyrighted document. Re-sale is strictly prohibited. The manufacturer may update this manual from time to time and cannot be responsible for problems, injuries, or damages arising out of the use of information contained in any manual obtained from unauthorized sources.

The kit contains:

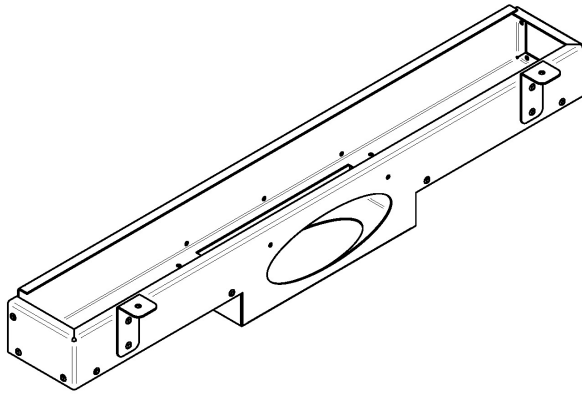

Air intake housing
(1x)

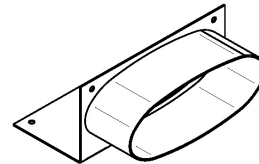

Air intake adapter
(1x)

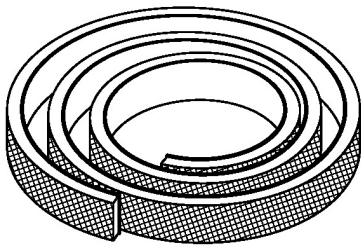

Flat self-adhesive gasket 5'
(1x)

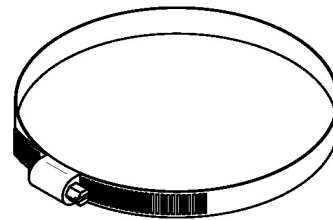

5" clamp
(2x)

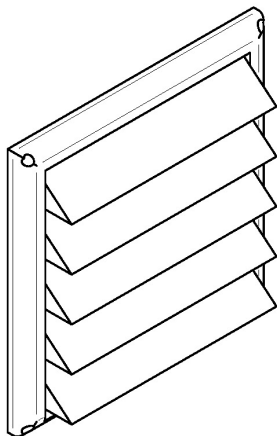

White 5" intake cap*
(1x)



Housing attachment screws
(8x)

***Note:** The fresh air intake must always come from outside of the house.

Items not included:

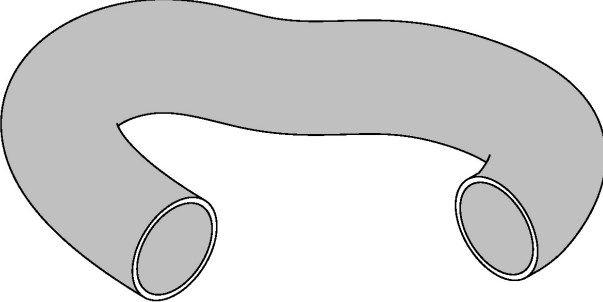
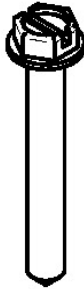
 <p>5" insulated pipe (1x)</p>	 <p>Intake cap attachment screws (4x)</p>
--	---

Note: To connect to the adapter, the ducting must be a HVAC type meeting ULC-S110 and/or UL-181. It must be rated for temperatures up to 250 °F.

Required tools:

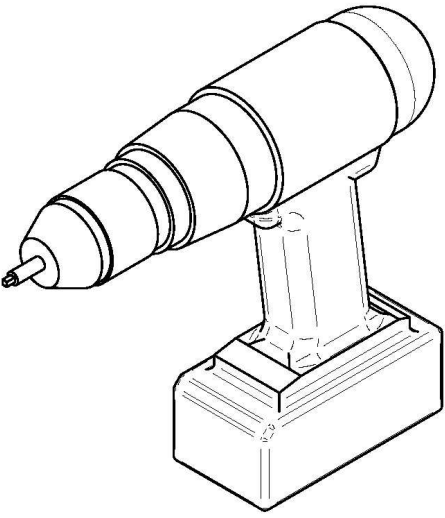
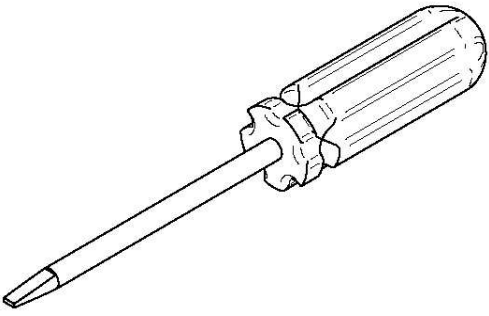
 <p>Powered drill with "quadrex" drill bit</p>	 <p>Flat head screwdriver</p>
---	---

Step 1:

Cut the self-adhesive gasket in 2 strips of 23 "(A) and 2 strips of 3" (B). Remove the protective film and install each length of gasket on top of the folds of the housing as shown in the drawing below.

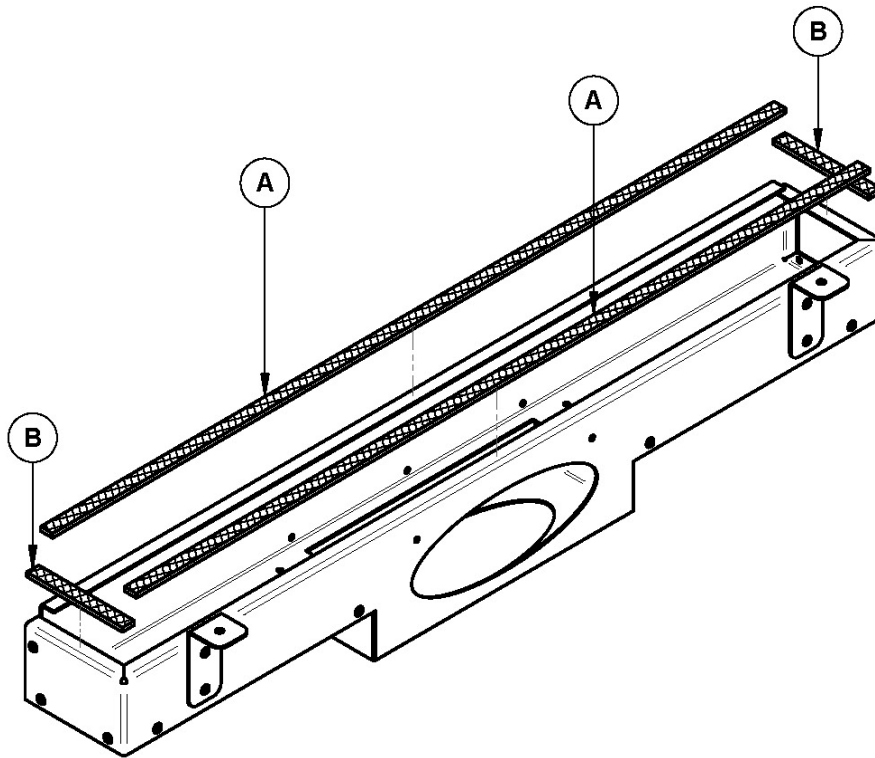

Step 2:

Install the oval adapter on the air intake housing according to the installation configuration you have chosen, towards the rear as in **(2a)** or towards the bottom as in **(2b)**.

2a) Adapter installation towards the rear: (4 screws required)

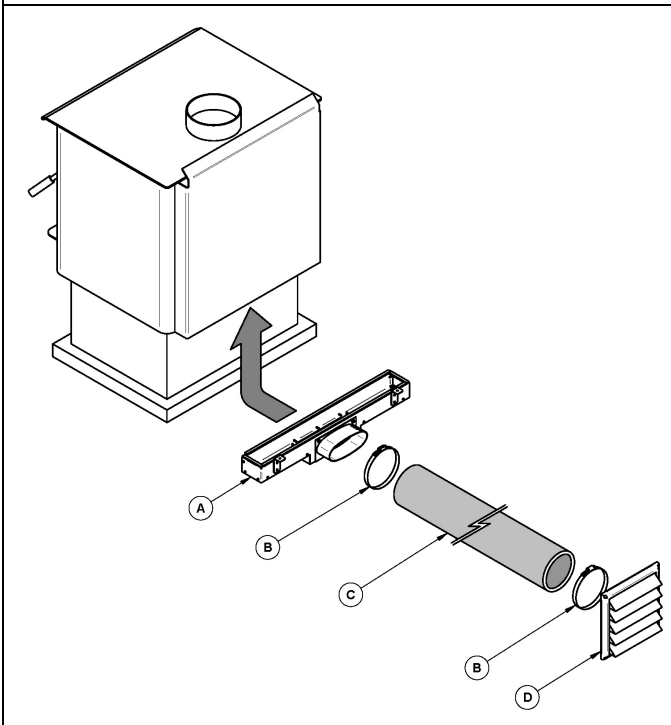
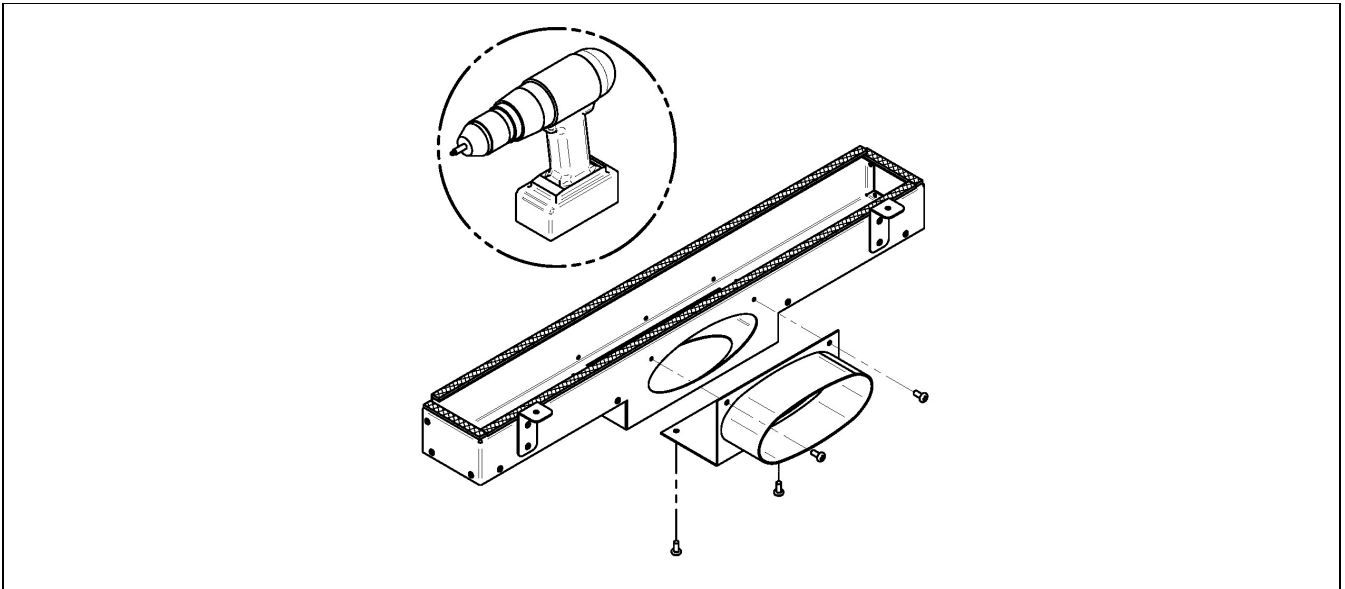

A- Air intake housing, B- Clamp, C- 5" insulated pipe (not included), D- Air intake cap.

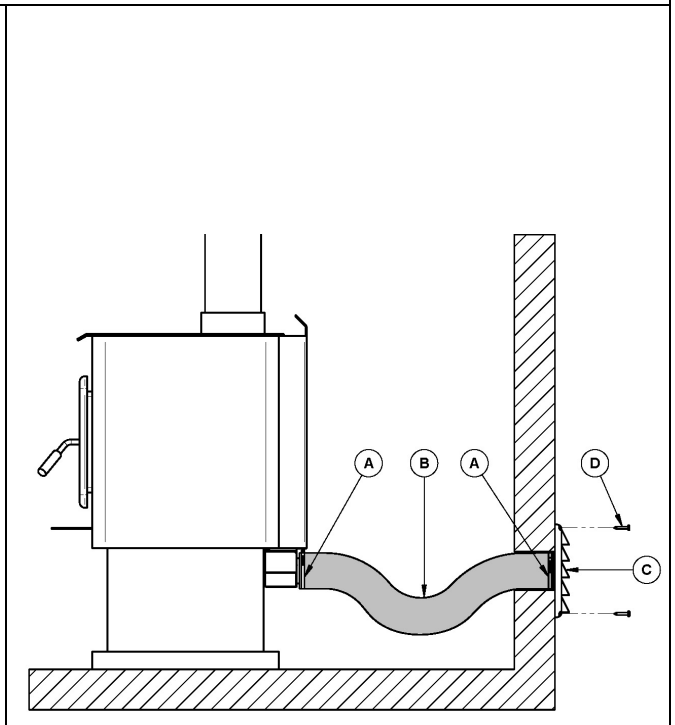

A- Clamp, B- 5" insulated pipe (not included), C- Air intake cap, D- Intake cap attachment screws (not included).

2b) Adapter installation towards the bottom: (4 screws required)

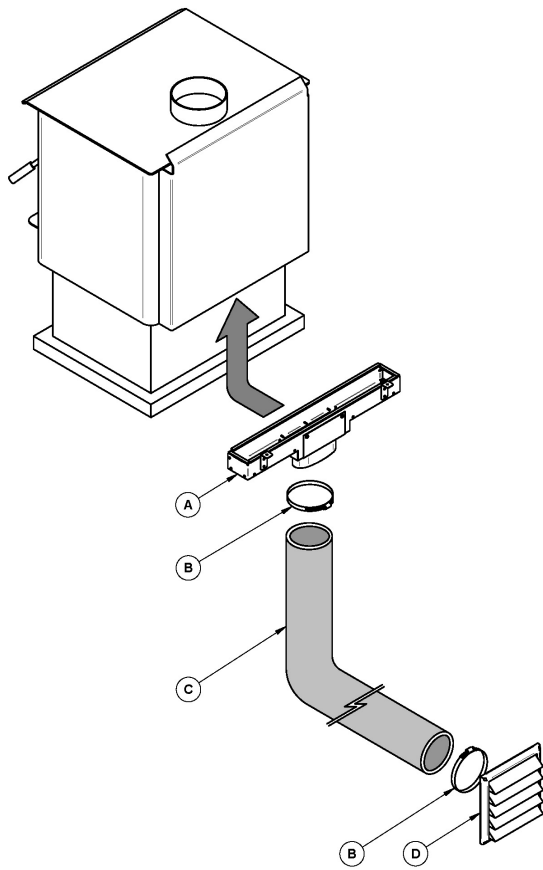
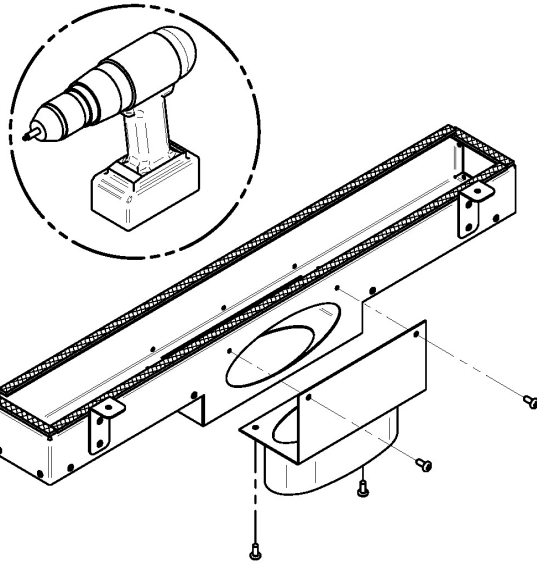

A- Air intake housing, B- Clamp, C- 5" insulated pipe (not included), D- Air intake cap.

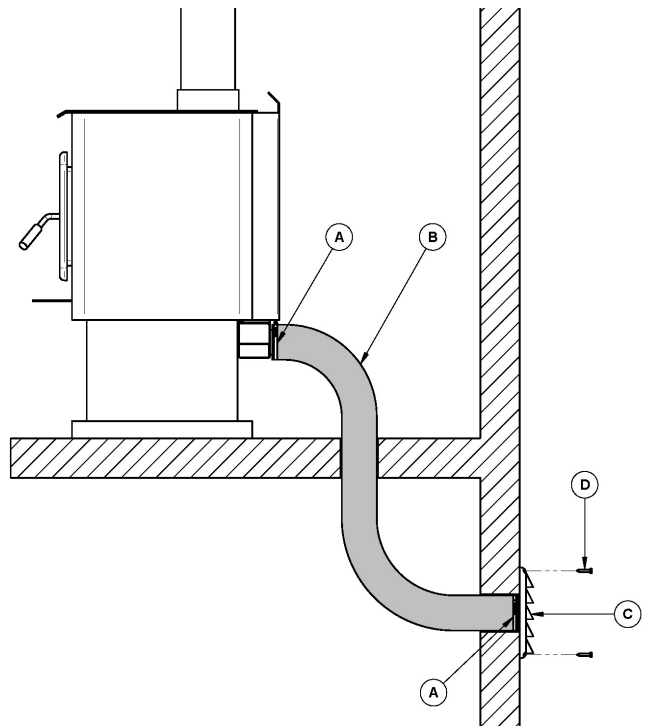

A- Clamp, B- 5" insulated pipe (not included), C- Air intake cap, D- Intake cap attachment screws (not included).

Step 3:

Align each hole in the 4 brackets installed on the housing with the holes on the underside of the rear heat shield (detail A) and the holes in the back plate of the pedestal (detail B). Using a powered drill, secure the housing assembly with 4 screws.

