

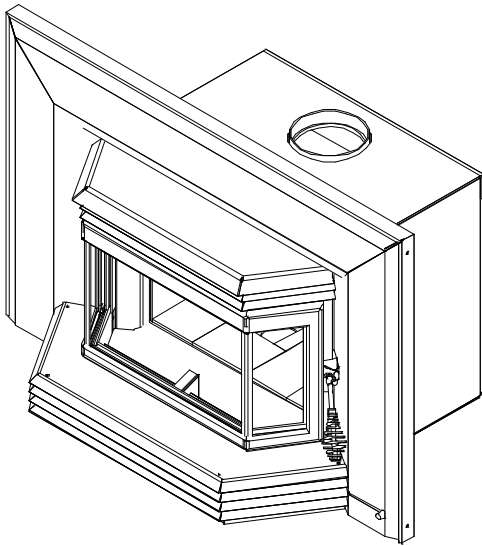

**BEYOND**  
fire

## OWNER'S MANUAL **1800 INSERT (OB01801 model)**



US ENVIRONMENTAL PROTECTION  
AGENCY PHASE II CERTIFIED  
WOOD INSERT

Verified and tested following  
ULC S627 and UL 1482 Standards by an  
accredited laboratory

Manufactured by: **STOVE BUILDER INTERNATIONAL INC.**  
250, rue de Copenhague, Saint-Augustin-de-Desmaures (Quebec) G3A 2H3  
After-sale service: 418-908-8002 E-mail: [tech@sbi-international.com](mailto:tech@sbi-international.com)  
[www.osburn-mfg.com](http://www.osburn-mfg.com)



*This manual is available for free download on the manufacturer's web site. It is a copyrighted document. Re-sale is strictly prohibited. The manufacturer may update this manual from time to time and cannot be responsible for problems, injuries, or damages arising out of the use of information contained in any manual obtained from unauthorized sources.*

**READ AND KEEP THIS MANUAL FOR REFERENCE**

# INTRODUCTION

SBI INC., one of the most important wood stove and fireplace manufacturers in Canada, congratulates you on your purchase and wishes to help you get maximum satisfaction from your wood stove. In the pages that follow, we will give you advice on wood heating and controlled combustion as well as technical specifications regarding installation, operation and maintenance of the model you have chosen.

The instructions pertaining to the installation of your wood stove comply with ULC-S627 and UL-1482 standards.

We recommend that our wood burning hearth products be installed and serviced by professionals who are certified in the United States by NFI (National Fireplace Institute®) or in Canada by WETT (Wood Energy Technical Training) or in Quebec by APC (Association des Professionnels du Chauffage).

**Read this entire manual before you install and use your new stove. If this stove is not properly installed, a house fire may result. To reduce the risk of fire, follow the installation instructions. Failure to follow instructions may result in property damage, bodily injury, or even death.**

**Consult your municipal building department or fire officials about restrictions and installations requirements in your area and the need to obtain a permit.**

**Keep this instructions manual for future references.**

## CAUTIONS:

- THE INFORMATION GIVEN ON THE CERTIFICATION LABEL AFFIXED TO THE APPLIANCE ALWAYS OVERRIDES THE INFORMATION PUBLISHED, IN ANY OTHER MEDIA (OWNER'S MANUAL, CATALOGUES, FLYERS, MAGAZINES AND/OR WEB SITES).
- HOT WHILE IN OPERATION. KEEP CHILDREN, CLOTHING AND FURNITURE AWAY. CONTACT MAY CAUSE SKIN BURNS.
- DO NOT USE CHEMICALS OR FLUIDS TO IGNITE THE FIRE.
- DO NOT LEAVE THE STOVE UNATTENDED WHEN THE DOOR IS SLIGHTLY OPENED.
- DO NOT BURN WASTES, FLAMMABLE FLUID SUCH AS GASOLINE, NAPHTHA OR MOTOR OIL.
- DO NOT CONNECT TO ANY AIR DISTRIBUTION DUCT OR SYSTEM.
- ALWAYS CLOSE THE DOOR AFTER THE IGNITION.

## **REGISTER YOUR WARRANTY ONLINE**

To receive full warranty coverage, you will need to show evidence of the date you purchased your stove. Keep your sales invoice.

We also recommend that you register your warranty online at <http://www.osburn-mfg.com/warranty-registration.aspx>

Registering your warranty online will help us track rapidly the information we need on your insert.

# TABLE OF CONTENTS

<b>INTRODUCTION.....</b>	<b>2</b>
<b>SECTION 1.0 PRE-INSTALLATION REQUIREMENTS.....</b>	<b>5</b>
1.1 MASONRY & ZERO CLEARANCE REQUIREMENTS .....	5
1.2 VENTING REQUIREMENTS .....	6
<b>SECTION 2.0 INSTALLATION.....</b>	<b>7</b>
2.1 SAFETY INFORMATION .....	7
2.2 INSTALLATION INSTRUCTIONS .....	8
2.3 COMPLIANCE OF THE MASONRY FIREPLACE .....	8
2.4 THE MASONRY FIREPLACE'S DRAFT CONTROL SYSTEM .....	9
2.5 COMPLIANCE OF A COMBUSTIBLE TOP SHELF.....	9
2.6 POSITIONING THE UNIT .....	10
2.7 MINIMUM MASONRY OPENING, CLEARANCES TO COMBUSTIBLES, AND FLOOR PROTECTOR.....	13
2.8 CONNECTOR INSTALLATION .....	15
2.8.1 CHIMNEY LINER INSTALLATION .....	16
2.8.1.1 IF THE CHIMNEY LINER DOES ALIGN WITH THE INSERT'S FLUE OUTLET, YOU HAVE TWO OPTIONS: .....	16
2.8.1.2 IF THE CHIMNEY LINER DOES NOT ALIGN WITH THE INSERT'S FLUE OUTLET: .....	17
2.9 AIR CONTROL PLATE, FACEPLATE AND FAN ASSEMBLY INSTRUCTIONS.....	18
<b>SECTION 3.0 OPERATION .....</b>	<b>21</b>
3.1 SAFETY INFORMATION .....	21
3.2 FUEL .....	22
3.2.1 SIMPLE WOOD MOISTURE TEST.....	22
3.3 NOTES ABOUT FIRST FIRING .....	23
3.4 LIGHTING A FIRE.....	23
3.5 MAINTAINING THE FIRE.....	24
3.6 FAN OPERATION .....	25
<b>SECTION 4.0 MAINTENANCE.....</b>	<b>26</b>
4.1 CARE AND CLEANING.....	26
4.1.1 GLASS CLEANING.....	26
4.2 ASH REMOVAL .....	26
4.3 CHIMNEY CLEANING.....	27
4.4 BAFFLE INSTALLATION AND BRICK NOTES: .....	27
4.5 SECONDARY AIR TUBE REPLACEMENT.....	30
4.6 FAN MAINTENANCE & CARE .....	31
<b>SECTION 5.0 TROUBLESHOOTING .....</b>	<b>31</b>
<b>SECTION 6.0 GENERAL INFORMATION ON 1800 INSERT (OB01801).....</b>	<b>32</b>
6.1 APPLIANCE PERFORMANCE <sup>(1)</sup> .....	32
6.2 GENERAL FEATURES .....	33
<b>OSBURN LIMITED LIFETIME WARRANTY .....</b>	<b>34</b>

# OUTSIDE DIMENSIONS

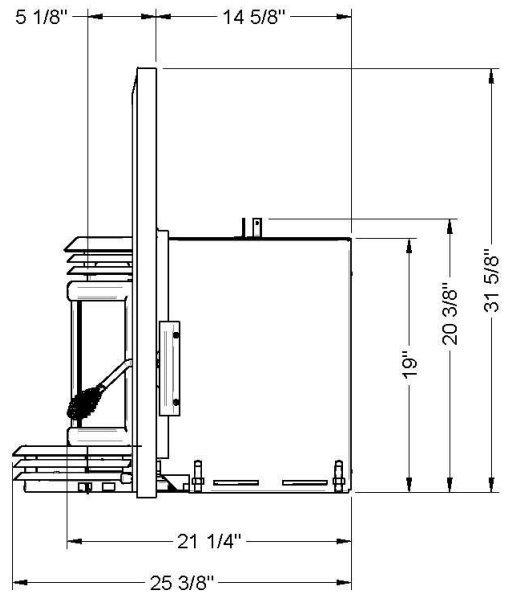
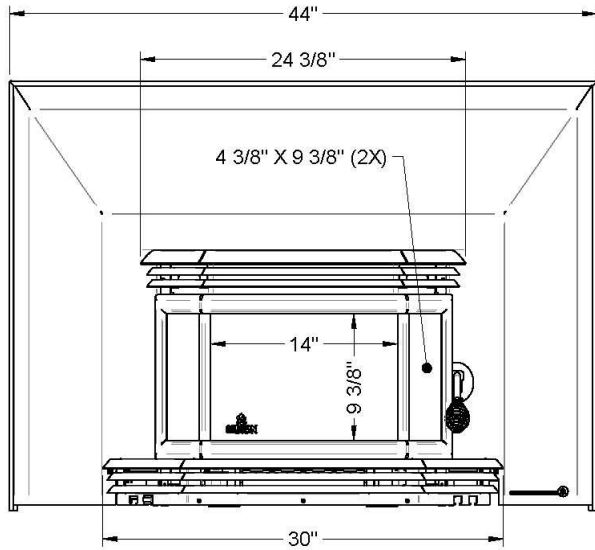
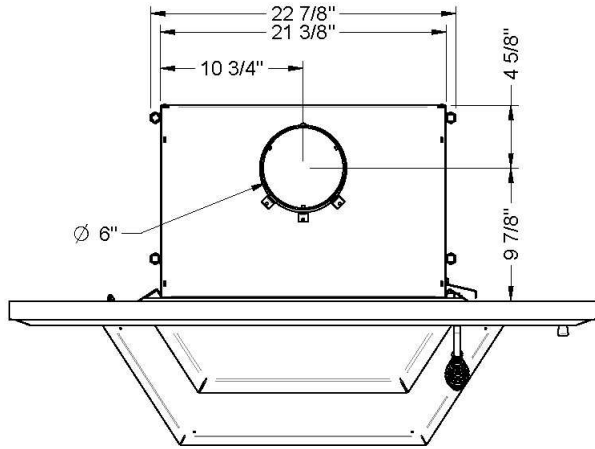

## Section 1.0 Pre-Installation Requirements

This unit is designed for safe operation. Altering or modifying the unit, or installation, without proper authorization will void the certification, warranty and safety listing and may result in a safety hazard.

### **1.1 Masonry & Zero Clearance Requirements**

The masonry fireplace must meet the minimum code requirements, or NFPA 211 in USA or CSA B365 in Canada or the equivalent for a safe installation. Contact your local Building Inspector for requirements in your area. An inspection of the fireplace should include the following:

1. **CONDITION OF THE FIREPLACE AND CHIMNEY:** Examine the masonry fireplace and chimney prior to installation to determine that they are free from cracks, loose mortar, creosote deposits, blockage, or other signs of deterioration. If evidence of deterioration is noted, the fireplace or chimney should be upgraded prior to installation.
2. **INSTALLATION INTO AN EXISTING FACTORY-BUILT ZERO-CLEARANCE FIREPLACE:** It is possible to install a wood insert into an existing factory-built zero-clearance fireplace. However, there currently exists no UL or ULC standard specific to that type of installation. The first thing that must be verified is that the factory-built zero clearance fireplace is listed (it must be certified by a competent certification body such as Omni or Warnock Hersey). It must be suitable for use with solid fuel and nothing in the owner's manual must specifically prohibit the installation of a fireplace insert. When in doubt, check with the fireplace manufacturer. The installation of the zero-clearance fireplace **MUST** be thoroughly inspected by a professional in order to ensure that it still meets the manufacturer's specs and code conformity. The chimney must be of at least 1" (25 mm) larger in diameter to accommodate a required continuous stainless steel liner running from the flue collar to the top of the chimney termination.  
  
Never remove parts that serve to insulate the zero-clearance fireplace from combustible material. Only readily detachable parts that are easily replaced, such as damper parts, screens, and doors, are to be removed from the fireplace. These parts must be stored nearby and available for retrofit if the insert is ever removed. Removal of any parts which render the fireplace unfit for use with solid fuel requires the fireplace to be permanently labelled by the installer as being no longer suitable for solid fuel until the removed parts are replaced and the fireplace is restored to its original certified condition. Furthermore, any air vents, grilles, or louvers that serve to create an air circulation pattern around and outside the zero-clearance fireplace shall never be removed.
3. **CHIMNEY CAPS:** Mesh type chimney caps must have provision for regular cleaning, or the mesh should be removed to eliminate the potential of plugging.
4. **LINER:** The chimney must have an acceptable masonry liner suitable for solid fuel, otherwise a continuous stainless steel liner must be installed.
5. **ADJACENT COMBUSTIBLES:** The fireplace should be inspected to make sure that there is adequate clearance to combustibles, both exposed combustibles to the top, side, and front as well as concealed combustibles, in the chimney and mantel area. Your local inspector should have information on whether older fireplaces are of adequate construction.
6. **OPENING SIZE:** Refer to "*Suitable Fireplace Dimensions*" for suitable size fireplace openings.

**NOTE: A METAL TAG IS PROVIDED AND IS TO BE FASTENED TO THE BACK WALL OF THE FIREPLACE, IF THE FIREPLACE HAS BEEN MODIFIED TO ACCOMMODATE THE INSERT.**

## **1.2 Venting requirements**

The flue is a critical component to a satisfactory installation. Your insert will attain its best performance if installed with a flue that generates its own draft. The minimum venting requirement will be the installation of a flue connector from the insert into the first tile of the chimney (see Figure 2.3). If you are using a masonry chimney, it is important that it be built in compliance with the specifications of the National Building Code or other applicable standard having jurisdiction. It must be lined with fire clay bricks, metal or clay tiles sealed together with fire cement (round flues are the most efficient). Ideally, the interior diameter of the masonry chimney should be identical to the insert smoke exhaust. You may also run a stainless steel liner inside the masonry chimney. A continuous 6" (152mm) stainless steel liner from the top of the chimney to the insert's smoke exhaust (see Figure 2.2) is the optimum system and will provide the best performance, as well as compensate for poor draft situations caused by large cross-sectional chimneys. The insert will not work without a positive seal in the chimney.

Chimneys constructed outside of the home, on an exterior wall, should be avoided if possible, especially in colder climates. Outside chimneys may not draw as well and may downdraft due to the difficulty in heating them up to operating temperature. Cooler chimneys will result in increased creosoting, less draft, and poorer performance. Draft is proportional to overall chimney height as well as to stack temperature. Draft can be increased by increasing chimney height, and by reducing heat loss from the chimney through an insulated liner.

Ensure that all joints in the flue systems are tightly sealed, since any leaks will result in reduced performance as well as a possible safety hazard. Using a fire screen at the extremity of the chimney requires regular inspection in order to insure that it is not obstructed thus blocking the draught, and it should be cleaned when necessary.

Do not connect this unit to a chimney flue serving another appliance.

This heating unit must serve as a supplementary heat source. An alternate heat source should be available in the home if needed. The manufacturer cannot be responsible for additional heating costs associated with the use of an alternative heat source.

It is recommended that the user buys this product from a retailer who can provide installation and maintenance advices.

## Section 2.0 Installation

### 2.1 Safety information

***NOTE: THIS APPLIANCE IS NOT RECOMMENDED FOR USE IN A HOME IF AN OCCUPANT HAS ANY RESPIRATORY OR ANY OTHER RELATED PROBLEMS.***

1. It is important to follow the installation and operation instructions. An improperly installed or operated insert could result in a safety hazard or fire, or damage to the unit, which would not be covered by the warranty. Contact local building or fire officials about restrictions and installation requirements in your area. You should be familiar with the installation and be sure that the work is done in accordance with this manual.

**WARNING: DO NOT INSTALL THIS INSERT IN A SLEEPING ROOM.**

2. Where lesser clearances are desired, consult your local authority as regulations may vary regarding the use of clearance reducing devices. Listed wall and floor shields are available to reduce clearances, and most building codes provide information on materials which may be used to reduce clearances.
1. Maintain at least the minimum clearances to combustible material as specified in this manual. Clearances are measured to the nearest part of the insert (i.e. top edge on the side). Clearances to any combustibles, when measured directly out from the front, must be a minimum of 48" (1219mm).
4. Maintain at least the minimum floor protection for combustible floor materials as specified in this manual. Floor protection to the front is to be measured from the fuel loading door opening.
5. Osburn recommends that you install a listed smoke detector or alarm in your home. Normal operation of the insert will have no effect on the detector or alarm.
6. The insert is to be connected only to a lined masonry chimney and masonry fireplace conforming to building codes for use with solid fuel. Do not remove bricks or mortar from the existing fireplace when installing the insert.
7. Minimum chimney size is 6" (152mm) diameter. Maintain a 15' (4.5m) minimum overall height measured from the base of the appliance. Chimneys should be inspected to check for deterioration and to determine if they meet the minimum requirements, and be upgraded if necessary. The chimney must extend at least 3' (914mm) above the roof and at least 2' (610mm) above the highest point within an area of 10' (3m) of the chimney.
8. Do not use makeshift compromises during installation, as they could create a safety hazard and a fire could result.
9. ***DO NOT CONNECT THIS APPLIANCE TO THE CHIMNEY OR FLUE SERVING ANOTHER APPLIANCE.***

## 2.2 Installation instructions

Inspect the masonry fireplace according to the safety information and fireplace requirements and have it cleaned and/or upgraded as necessary.

## 2.3 Compliance of the masonry fireplace

Where the masonry fireplace opening is  $6 \text{ ft}^2$  ( $0.56 \text{ m}^2$ ) or larger, the hearth extension shall extend at least 20" (508 mm) in front of the facing material and at least 12" (305 mm) beyond each side of the fireplace opening. Where the masonry fireplace opening is less than  $6 \text{ ft}^2$  ( $0.56 \text{ m}^2$ ), the hearth extension shall extend at least 16" (406 mm) in front of the facing material and at least 8" (203 mm) beyond each side of the fireplace opening.

Note that if you must modify the hearth extension to comply with these measures, depending on the size of the masonry fireplace opening, the hearth extension must have a minimum of 4" (102 mm) thick (see Figure 2.6a and 2.6b.)

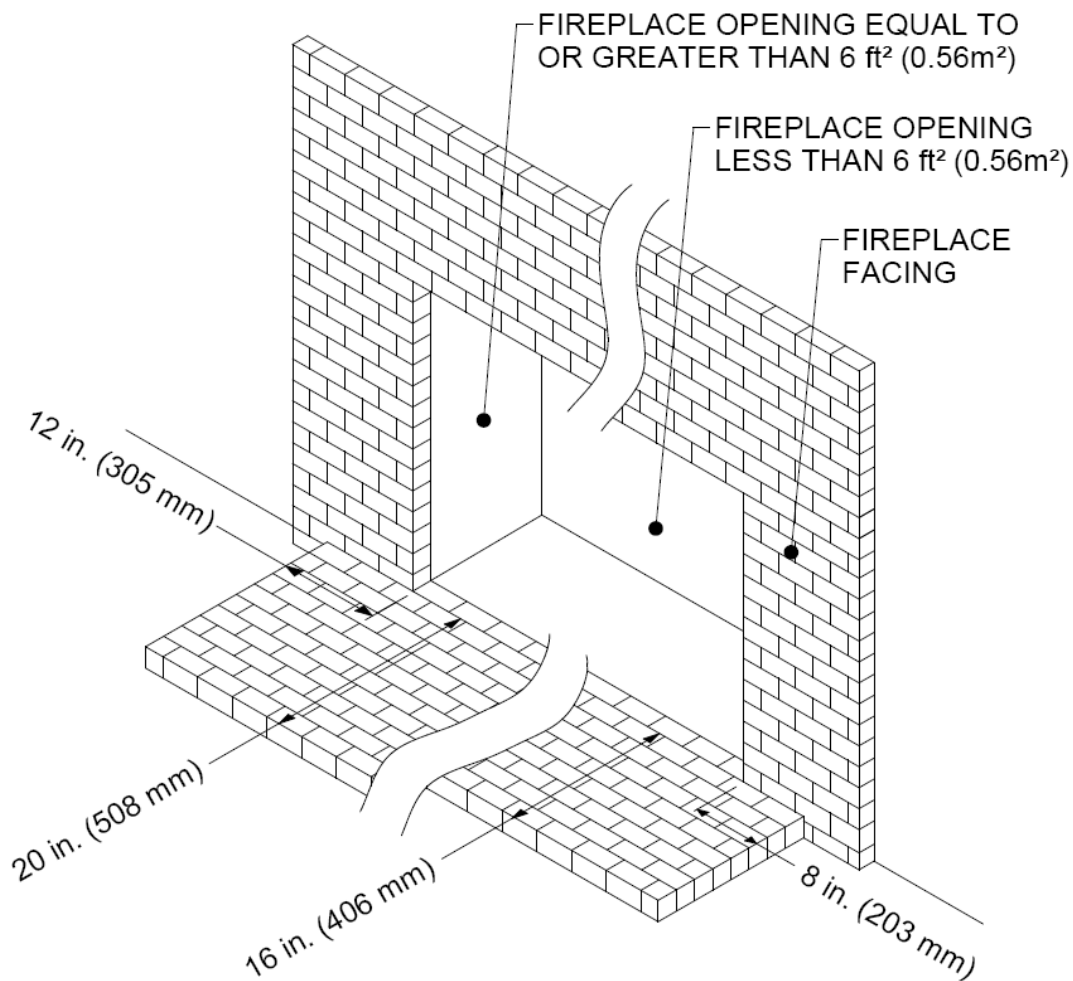



## **2.4 The masonry fireplace's draft control system**

If the fireplace's draft control system is to remain in the masonry fireplace, it must be locked open for access of the chimney liner or removed entirely. If you remove draft control system from the masonry hearth, you will need to install the metal plate (27009), supplied with the owner's manual kit, indicating that the masonry hearth has been modified. It must be secured inside the masonry hearth, in a visible place and easy to locate.

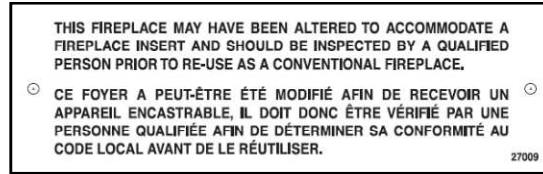

## **2.5 Compliance of a combustible top shelf**

To ensure compliance of an existing top shelf or to install any combustible shelf, refer to table below and Figure 2.5 for a safe installation or to perform changes if necessary. For example, a shelf with a 6" depth (152 mm) must be installed at least 22" (559 mm) above the top of the insert (see Figure 2.5). Different shelf dimensions are listed in the following table in order to facilitate installation. However, no combustible shelf can be installed at less than 22" (559 mm) above the top of the insert. If the depth of the shelf is not listed in the table, add 16" (406 mm) to the depth of your shelf to obtain the safe positioning of your shelf. For example, for a 9" (229 mm) shelf, the safe positioning would be 25" (635 mm) above the top of the insert (16" (406 mm) + 9" (229 mm)).

<b><i>SHELF POSITIONING</i></b>	
<b>MAXIMUM SHELF DIMENSION (X)</b>	<b>SHELF POSITION (I)</b>
<b><i>6" / 152 mm</i></b>	<b><i>22" / 648 mm</i></b>
<b><i>8" / 203 mm</i></b>	<b><i>24" / 698 mm</i></b>
<b><i>10" / 254 mm</i></b>	<b><i>26" / 749 mm</i></b>
<b><i>12" / 305mm</i></b>	<b><i>28" / 800 mm</i></b>

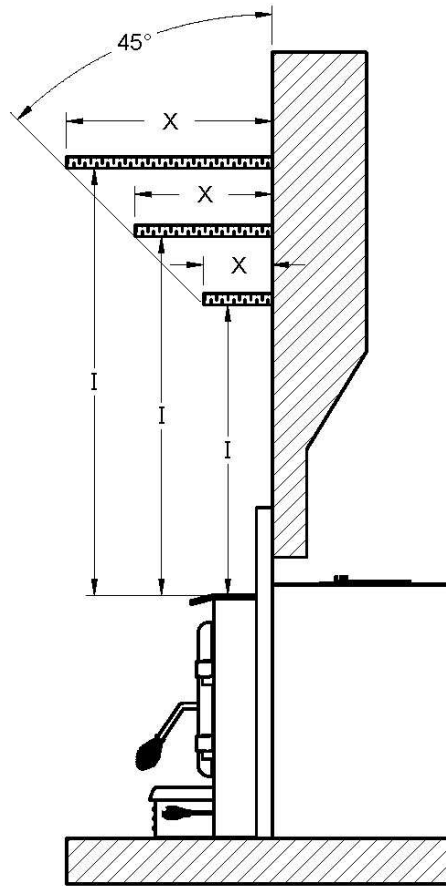

## 2.6 Positioning the unit

In addition to ensuring compliance of the masonry fireplace hearth extension (see *Compliance of the masonry fireplace* in Section 2.3), it is necessary to have a floor protection made of non-combustible materials that meets the measurements specified in table *FLOOR PROTECTION* (see Section 2.7). To determine the need to add a floor protection (D) beyond the hearth extension, you must do the following calculation using the data in Table *Data for floor protection calculation* of this section:  $D = B - (A - C)$ . If the value (D) is negative or zero, you do not have to add more floor protection in front of the unit, because the masonry fireplace hearth extension is long enough. If the value (D) is positive, you will need a floor protection in front of the hearth extension at least equivalent to the result (D).

Here is a sample calculation to determine the need to add a non-combustible materials floor protection. For someone living in the USA whose fireplace opening is less than 6 ft<sup>2</sup> and which the insert would protrude 3" (76 mm) into the room (C) the calculation would be:

$$\text{Value D} = B - (A - C)$$

$$\text{Value D} = 16" - (16" - 3")$$

$$\text{Value D} = 16" - 13"$$

$$\text{Value D} = 3"$$

This person should install a non-combustible floor protection of at least **3" (76 mm)** in front of the fireplace hearth extension.

If a non-combustible material floor protection needs to be added in front and level with the hearth extension masonry fireplace (see Figure 2.6a), an R factor equal to or greater than 1.00 is required. If the extension of the masonry hearth is raised at least 4" from the floor protection (see Figure 2.6b), a non-combustible material without an R factor is sufficient.

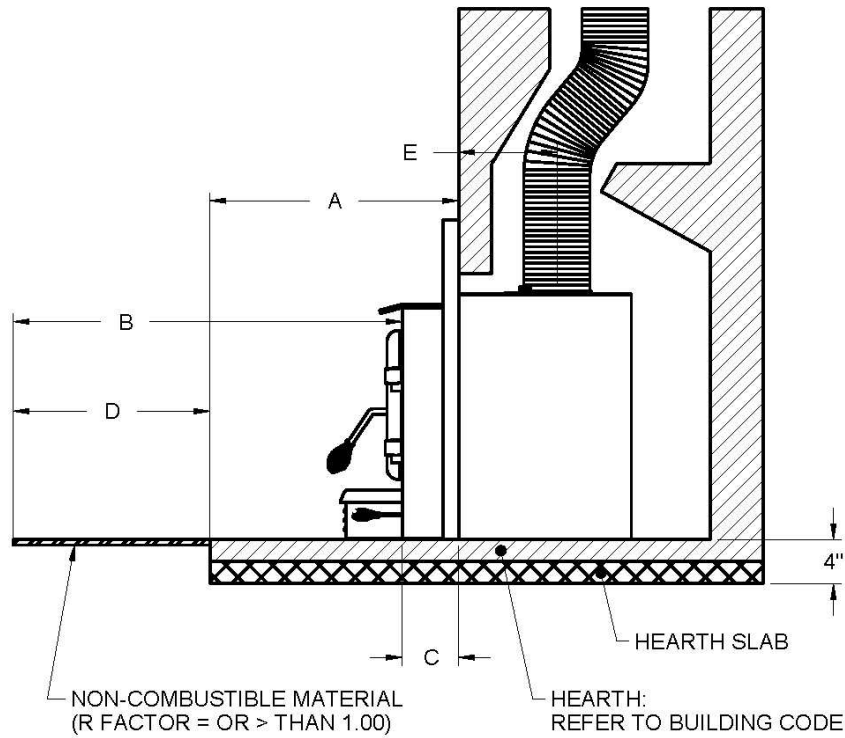

Figure 2.6a

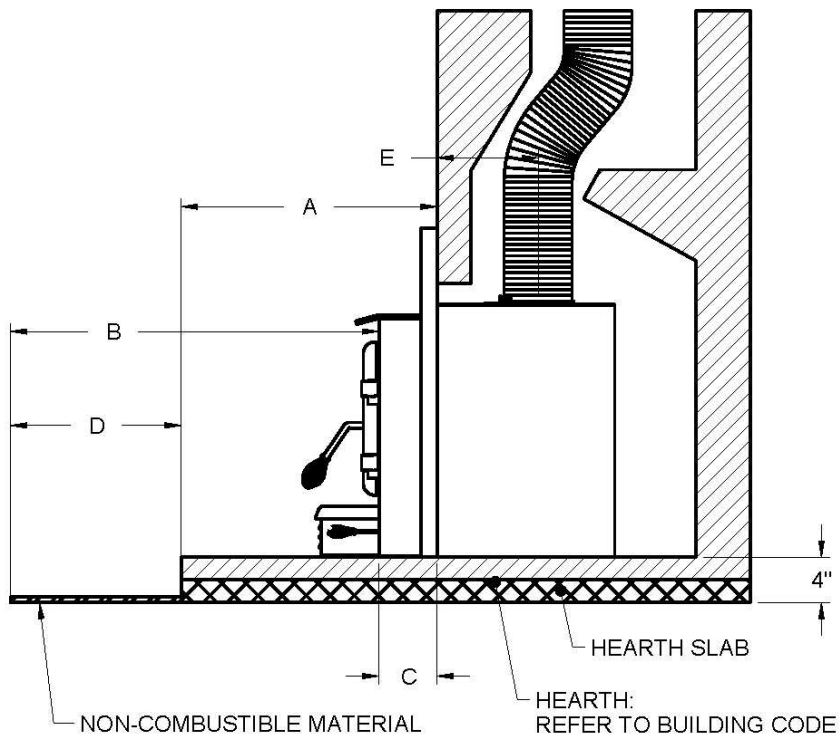

Figure 2.6b

The use of an R value is convenient when more than one material is going to be used in the hearth extension to cover the combustible surface. This is because R values are additive, whereas K values are not. To find the corresponding R factor to use for some selected materials, please see Table *Thermal characteristics of common floor protection materials* in this section.

There are two ways to calculate the R factor of the floor protection. First, by adding the R-values of materials used, or by the conversion if the K factor and thickness of the floor protection are given.

To calculate the total R factor from R factors of the materials used, simply add the R-values of materials. If the result is equal to or greater than the R-value requirements, the combination is acceptable. To know the R-values of some selected materials, see table *Thermal characteristics of common floor protection materials*.

**Example:**

Required floor protection R of 1.00. Proposed materials: four inches of brick and one inch of Durock<sup>®</sup> board

Four inches of brick ( $R = 4 \times 0,2 = 0,8$ ) plus 1 inch of Durock<sup>®</sup> ( $R = 1 \times 0.52 = 0.52$ ).

$$0.8 + 0.52 = \mathbf{1.32.}$$

This R value is larger than the required 1.00 and is therefore **acceptable**

In the case of a known **K** and thickness of alternative materials to be used in combination, convert all **K** values to R by dividing the thickness of each material by its **K** value. Add the **R** values of your proposed materials as shown in the previous example.

**Example:**

K value = 0.75

Thickness = 1

$$R \text{ value} = \text{Thickness}/K = 1/0.75 = 1.33$$

**Data for floor protection calculation**

	A		B (Note 1)	C	E
	Smaller than 6 ft <sup>2</sup> *	Bigger or = to 6 ft <sup>2</sup> *			
INCHES	16"	20"	CAN: 18" USA: 16"	5 3/8"	9 7/8"
MILLIMETRE S	406 mm	508 mm	CAN: 457 mm USA: 406 mm	137 mm	251 mm

\*Refers to masonry fireplace opening.

## Thermal characteristics of common floor protection materials\*

MATERIAL	CONDUCTIVITY (k) PER INCH	RESISTANCE (R) PER INCH THICKNESS
Micore <sup>®</sup> 160	0.39	2.54
Micore <sup>®</sup> 300	0.49	2.06
Durock <sup>®</sup>	1.92	0.52
Hardibacker <sup>®</sup>	1.95	0.51
Hardibacker <sup>®</sup> 500	2.3	0.44
Wonderboard <sup>®</sup>	3.23	0.31
Cement mortar	5.00	0.2
Common brick	5.00	0.2
Face brick	9.00	0.11
Marble	14.3 – 20.00	0.07 – 0.05
Ceramic tile	12.5	0.008
Concrete	1.050	0.950
Mineral wool insulation	0.320	3.120
Limestone	6.5	0.153
Ceramic board (Fibremax)	0.450	2.2
Horizontal still air** (1/8")	0.135	0,920**

\* Information as reported by manufacturers and other resources

\*\* For a 1/8" thickness. You cannot «stack» horizontal still air to accumulate R-values; you must separate each later of horizontal still air with another noncombustible material.

### 2.7 Minimum masonry opening, clearances to combustibles, and floor protector

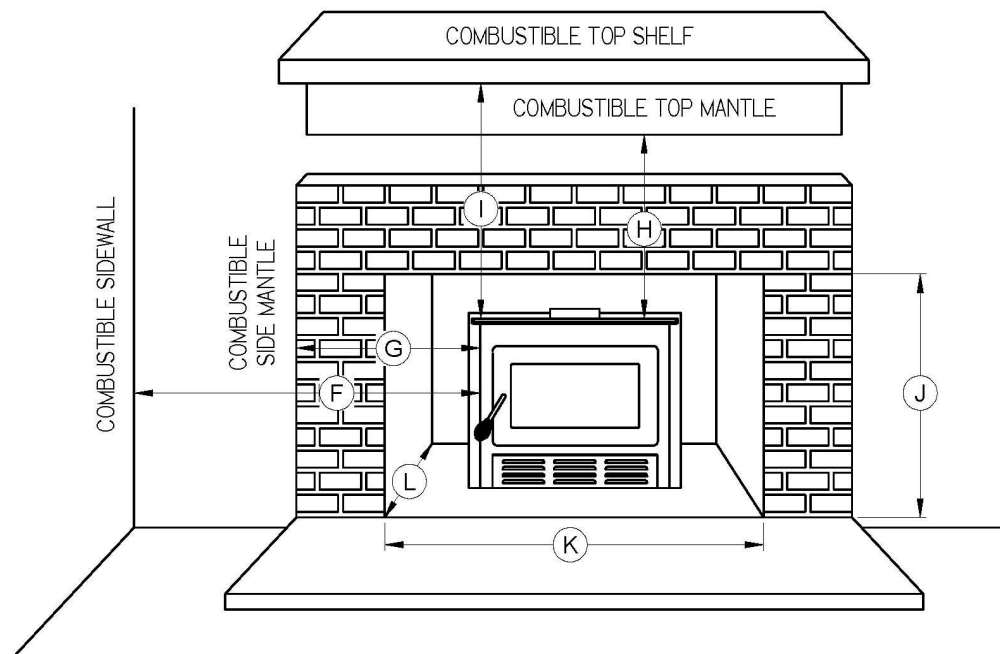

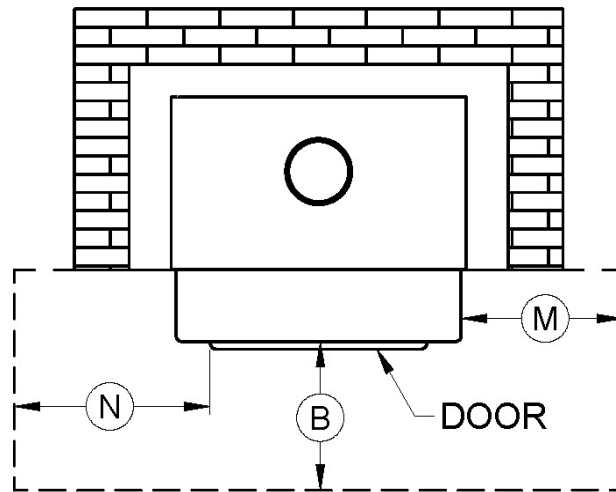

	<b>MINIMUM MASONRY OPENING</b>
<b>J</b>	20" (508 mm)
<b>K</b>	23 3/8" (594 mm)
<b>L</b>	14 5/8" (371 mm)

	<b>CLEARANCES</b>
<b>F</b>	17" (432 mm)
<b>G</b>	10" (254 mm)
<b>H</b>	14" (356 mm)
<b>I</b>	22" (559 mm)

	<b>FLOOR PROTECTOR</b>	
	<b>CANADA</b>	<b>USA</b>
<b>B</b>	18" (457 mm) – Note 1	16" (406 mm) – Note 1
<b>M</b>	8" (203 mm)	N/A (Canada only)
<b>N</b>	N/A (USA only)	8" (203 mm)

\* For a 6" (152 mm) shelf. See Table *SHELF POSITIONING* (Section 2.5) for other shelf dimensions.

**Note 1:** From door opening. The depth of a non-combustible shelf in front of the insert is included in the calculation of the floor protector's dimensions.

**IMPORTANT:** The masonry hearth should be at least 4 inches (102 mm) higher than the combustible floor in front of it. If the hearth elevation is lower than 4 inches, the non-combustible floor protector in front of the insert should have an R value equal or greater than 1.00.

## 2.8 Connector installation

A masonry flue connector may provide acceptable performance (Figure 2.8a); however, we recommend the use of a chimney liner (rigid or flexible) to ensure satisfactory performance (Figure 2.8b). To ensure an optimal draft, we also strongly recommend adding a minimum of 18" rigid liner between the roof flashing and the rain cap. Slip connectors for continuous liners should also be installed. Use Listed Chimney Liners – UL1777, CAN/ULC-S635.

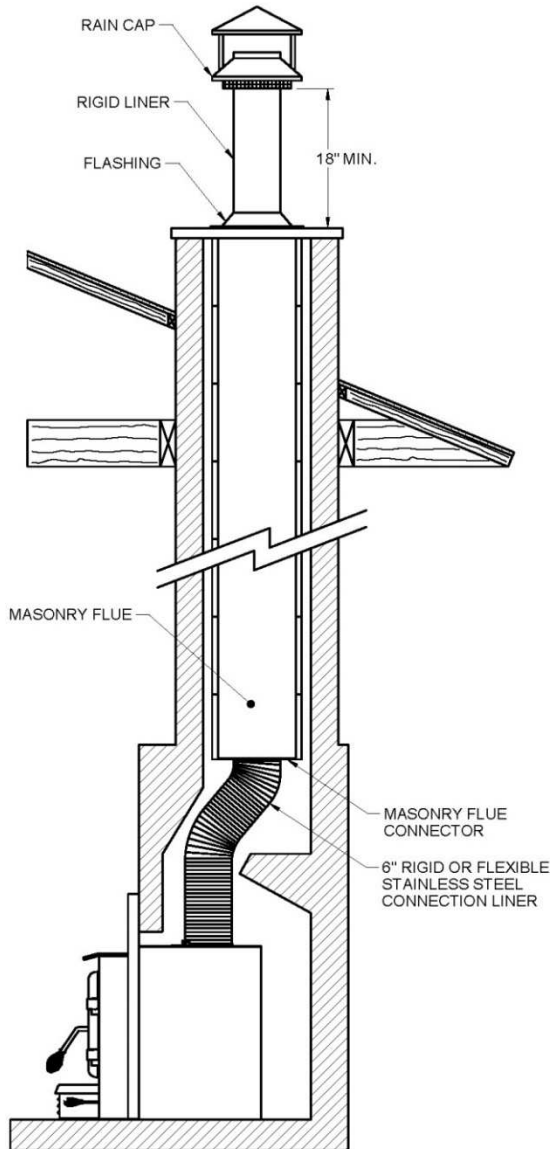

Figure 2.8a\*

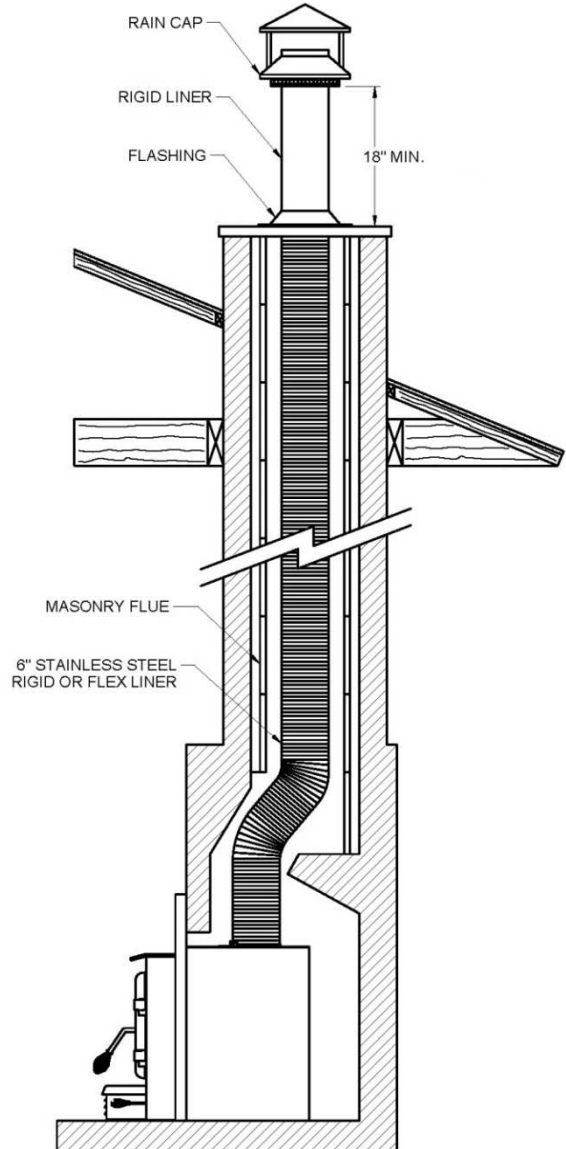

Figure 2.8b\*

\* Generic illustrations. The model of your insert can differ from the one shown above.

**ATTENTION INSTALLER:** When positioning the unit in a fireplace opening prior to the flue installation, install the insert into the opening until the top lip of air jacket is flush with fireplace facing.

If lag-bolts and anchors are to be used to secure the insert, the whole locations should be marked with the unit in place. Remove the insert and locate the anchors.

## **2.8.1 Chimney liner installation**

To install of the chimney liner, the preferred methods are those found in Section 2.8.1.1. Use a liner offset adapter (Section 2.8.1.2) only as a last resort.

### **2.8.1.1 If the chimney liner does align with the insert's flue outlet, you have two options:**

- A) Install the chimney liner starter adapter, provided with the chimney liner. Follow the chimney liner starter adapter manufacturer's instructions.

In order to connect the chimney liner starter adapter to the flue outlet, you can install the brackets with the screws that are in the instruction manual kit.

Using a powered driver, secure the three brackets with the three screws provided 30131 on top of the insert in the three holes in front of the flue outlet. The long end of the brackets must be attached to the insert. Insert the chimney liner into the flue collar of the unit and secure the liner to the brackets with three self-tapping screws (not included).

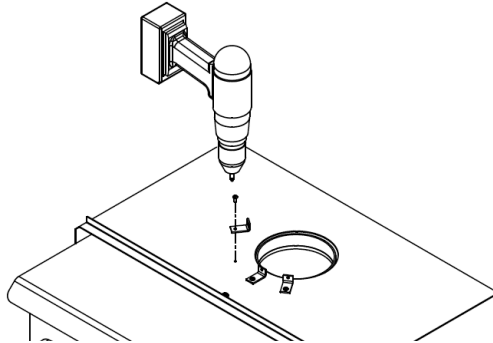

- B) You can get from your dealer a liner fixation system (AC02006), sold separately. Follow the installation instructions provided with the liner fixation system.

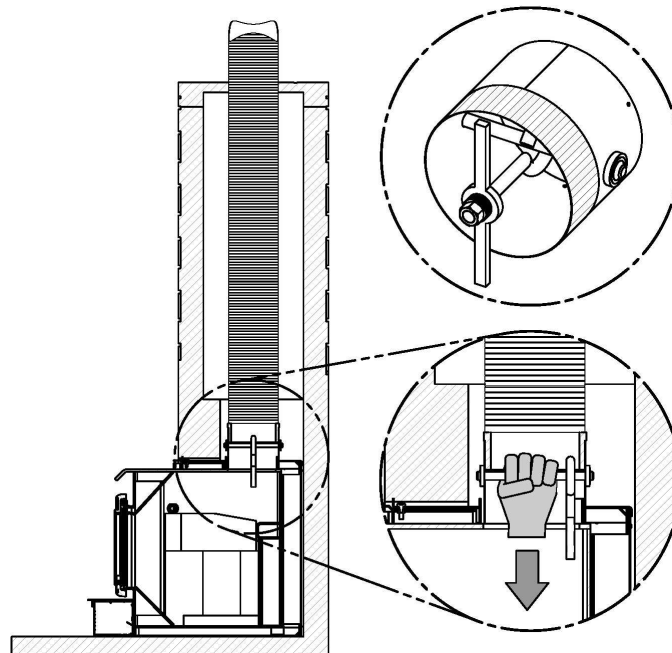



**2.8.1.2 If the chimney liner does not align with the insert's flue outlet:**

You can get a liner offset adapter (AC01370), sold separately. If you must install a liner offset adapter, using a powered driver, secure the three brackets with the three screws provided 30131 on top of the insert in the three holes in front of the flue outlet. The long end of the brackets must be attached to the insert. The brackets and screws are in the insert's instruction manual kit. Then follow the instructions in the manual provided with the liner offset adapter kit.

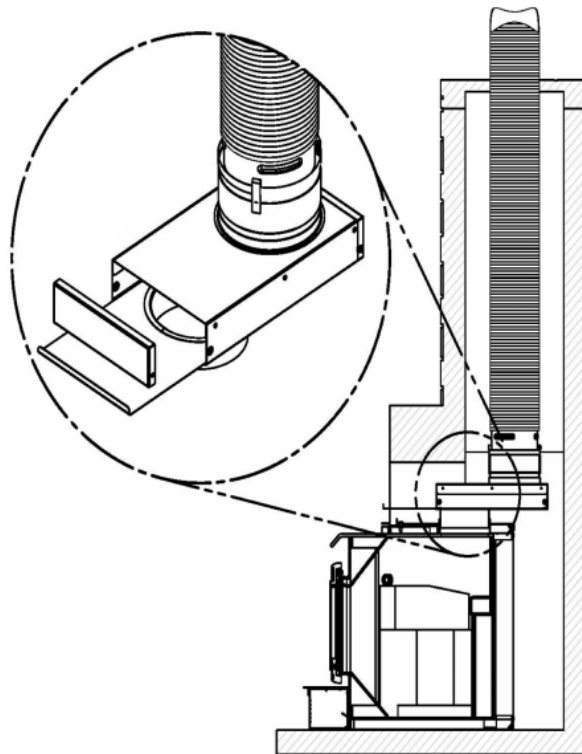
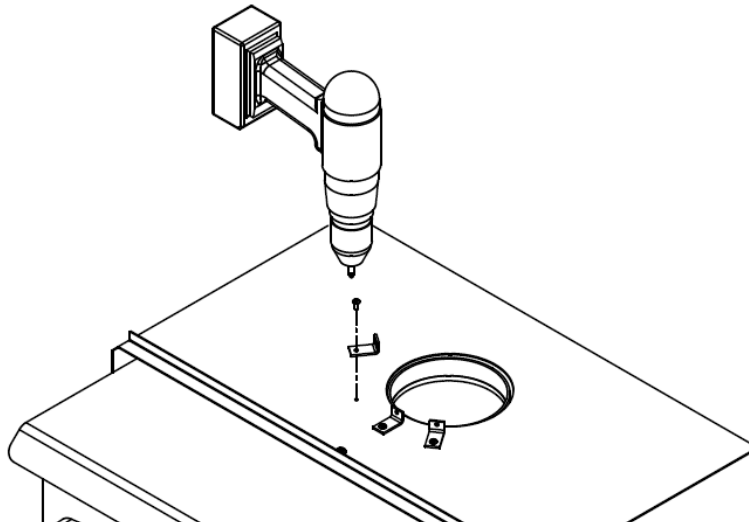

## **2.9 Air control plate, faceplate and fan Assembly Instructions**

1. Place the faceplate panels with the finished side down on a flat, soft, non-abrasive surface.
2. Assemble the faceplate trim, attaching the mitered corners with the corner brackets. (see Figure 2.9c)
3. Line up the holes of the side and top panels and secure with the six (6) screws, washers and nuts. (see Figure 2.9d)
4. Slide the assembled trim over the edges of the faceplate.
5. Secure trim to faceplate using eight "U" shaped brackets. (see Figure 2.9d)
6. Locate air control plate Fig 2.9a (shipped inside firebox). Slide air control into tracks on firebox bottom as indicated in Fig 2.9b.

Figure 2.9a

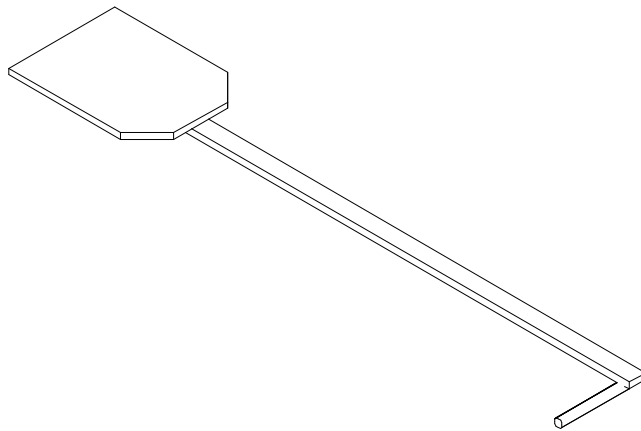
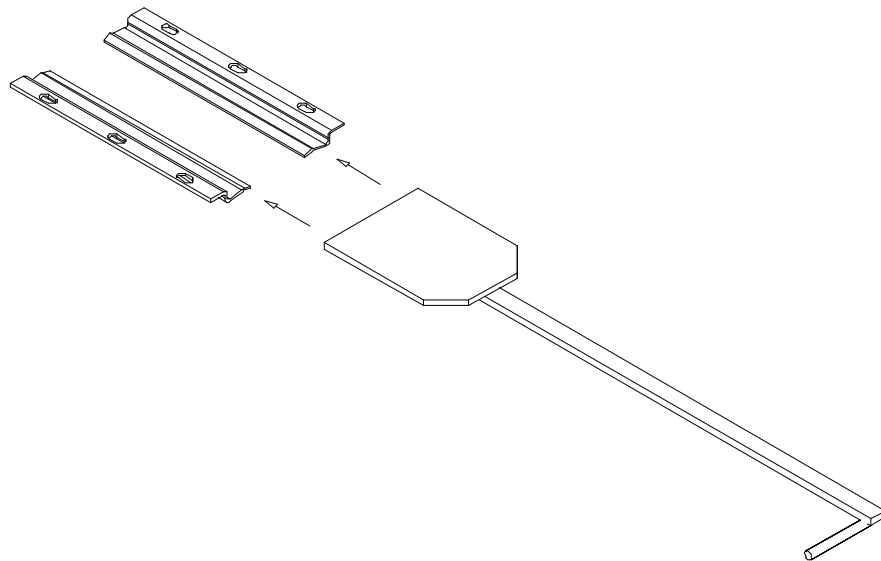

Figure 2.9b



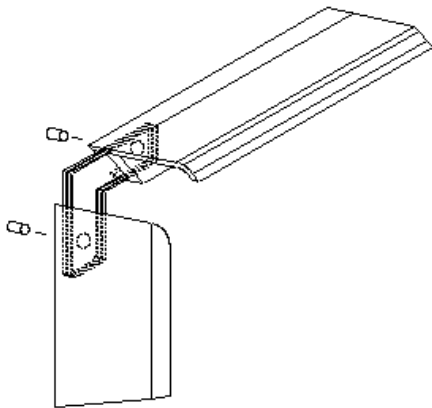

Figure 2.9c

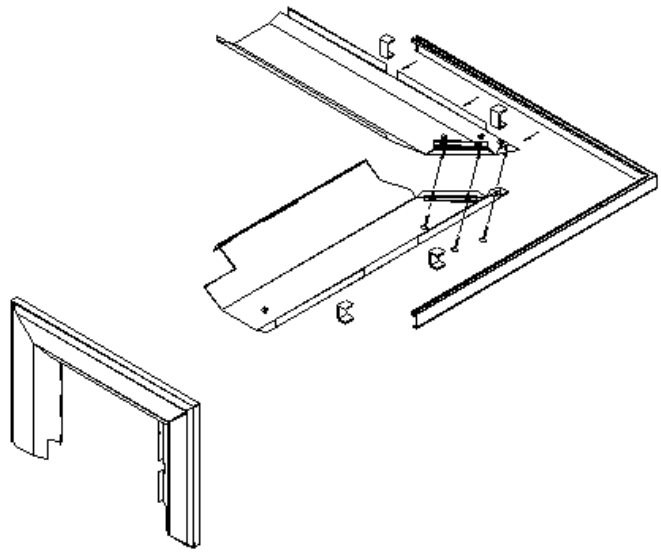

Figure 2.9d

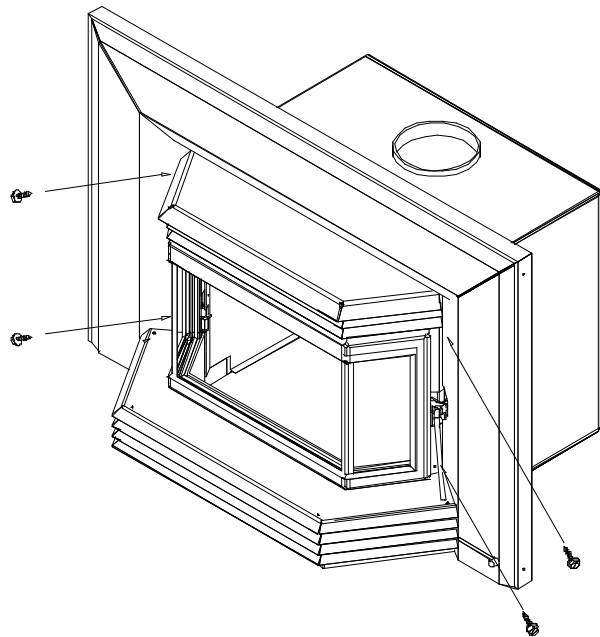

Figure 2.9e

7. Fan is already attached to the unit at the factory with two tie straps. Remove the tie straps and secure the fan to unit.

8. Cooktop is installed at the factory. Shipping screw must be removed before installation of faceplates. (Figure 2..9f)
9. Install faceplate (Figure 2.9e) with four (#10 x 3/8" sheet metal) screws supplied, ensuring the 1/4" rod on the air control plate extension protrudes through the slot in the RH faceplate & moves freely horizontally.
10. Add the air control knob (Figure 2.9h).

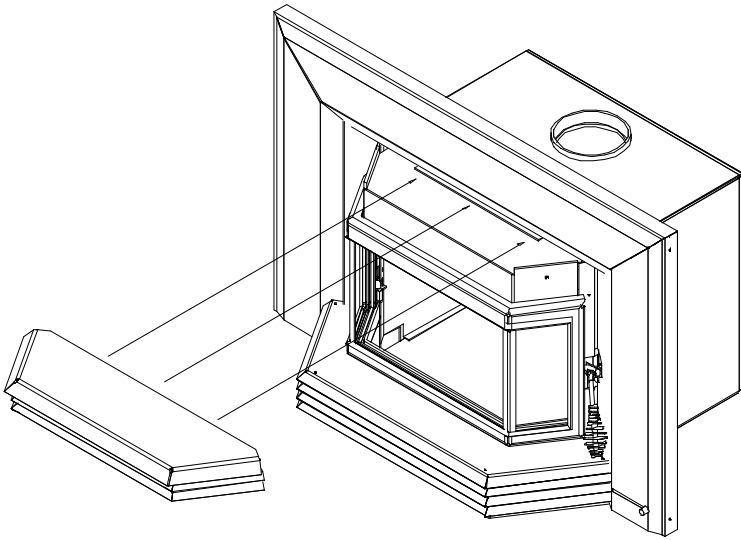

Figure 2.9f

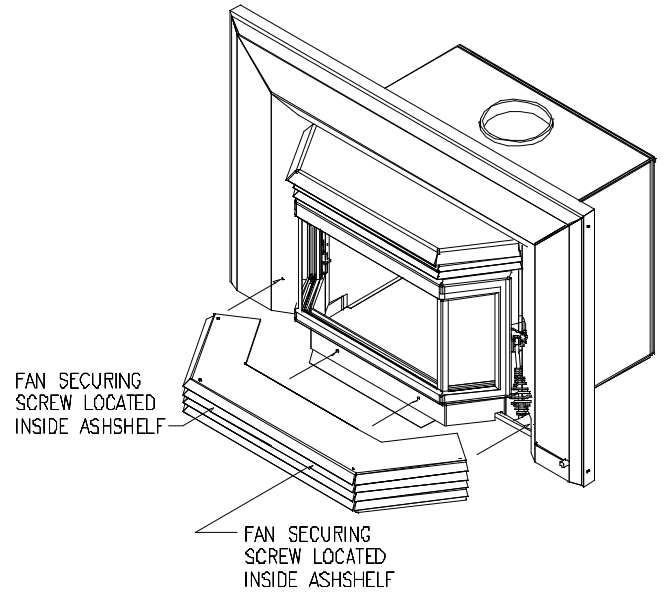

Figure 2.9g

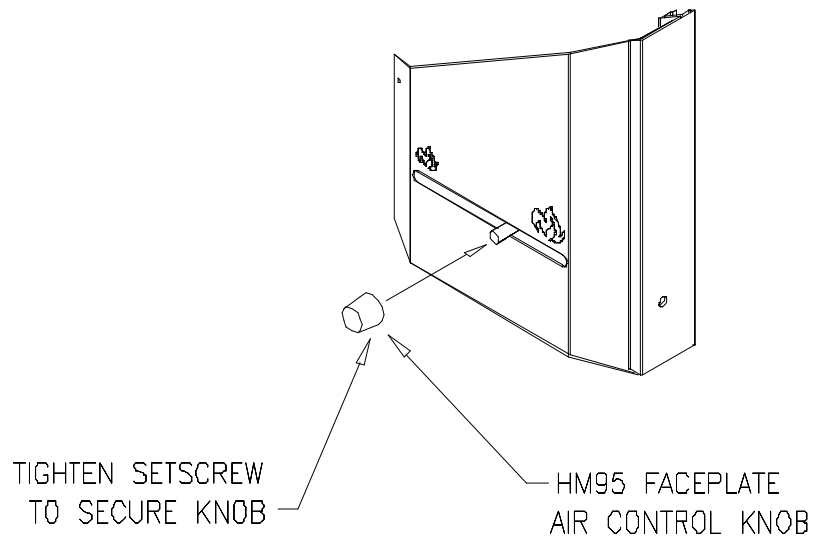

Figure 2.9h

## Section 3.0 Operation

### 3.1 Safety Information

1. This insert is designed for safe operation *WHEN BURNING CORDWOOD ONLY*. Altering or modifying the unit or the installation without proper authorization will void the certification, warranty, and safety listing, and may result in a safety hazard.
2. For safety reasons, never leave the unit unattended with the door open or ajar. An open door, and especially a door partially open or cracked, if left for longer than required for good ignition can potentially result in unsafe chimney temperatures, and if left unattended, hot embers or ignited fuel may fall out of the unit. Prolonged door open operation is not necessary provided the unit has been properly installed and dry kindling is used to start the fire.
3. Do not abuse the unit, either by over firing or by using wood or combustibles with salt content, or harmful chemicals. Misuse is not covered by warranty.
4. Even though your Osburn has been specifically designed and tested to prevent smoke spillage, always open the door slowly as this will minimize the likelihood of smoke spillage or a back draft causing flame or smoke to spill into the room.
5. Never use gasoline type lantern fuel, kerosene, solvents, charcoal lighter fluid, or inflammable liquids to start or "freshen" a fire in the insert. Keep all such liquids well away from the insert while it is in use.
6. All insert surfaces become very hot during operation. Care is needed, especially with children, to avoid contacting these surfaces.
7. Do not elevate the fire by means of grates, and irons or other means.
8. **CAUTION: DO NOT OVER FIRE THIS HEATER.** Do not burn fuel in the insert at a rate higher than that which will cause the ember bed level to exceed half the door opening height. If the door handle of the insert becomes excessively hot to the touch, consider this to be an indication of over firing. Over firing can result in a safety hazard and can permanently damage the insert and chimney. This damage is not covered by the warranty.
9. Although the ceramic glass is extremely durable under any normal use, a few precautions are required. Do not attempt to push logs further into the fire by using the door, as the glass may break if it is heavily contacted by any solid object.  
  
Never operate the insert with the door open, or cracked slightly open, except briefly during the lighting operation, and during refuelling. Leaving the door open continuously could seriously overheat the chimney and adjacent combustibles. Do not operate the insert if there is an abnormal air leakage into the unit, such as through deteriorated gaskets or cracked or broken glass. Do not operate the insert without a door gasket. Leakage can result in overheating, or in very airtight homes, could possibly cause smoke spillage into the room. Smoke may contain carbon monoxide, which is poisonous, and in sufficient quantities is a health hazard.
10. We recommend that you have a fresh air or make up air supply for the insert. In Canada this is a building code requirement. If this is not done, it could cause poor air quality in the home, poor and incomplete combustion, and poor efficiency in the insert.

## **3.2 Fuel**

1. Fuel for the insert must not be stored closer than the required clearances to combustibles and not in the space required for ash removal.
2. Your Osburn insert is designed to burn ***CORDWOOD FUEL ONLY***. Do not burn coal, charcoal, or trash in the unit. Highly flammable items such as trash may ignite creosote in the chimney, resulting in a chimney fire. Never burn salt wood, beachwood, chemically treated wood, or wood removed from salt water, since the deposits left will deteriorate the firebox. Damage caused by chemicals or salt is not covered under warranty.
3. Seasoned dense wood is recommended. Wood should be air dried in a covered ventilated area for six months to a year or more. This reduces the moisture content of the wood, resulting in better insert performance. Wood species with a moisture content of 20% or less are ideal. Dry seasoned wood can be distinguished from green wood by the checks or cracks in the ends.
4. Wet or green wood will tend to cause the fire to smoulder, producing large amounts of creosote. Creosote build-up could result in a chimney fire. This wood will also prove difficult to keep burning properly, and fires will tend to go out. Green wood produces very little heat, and sometimes causes customers to think that the insert does not work. If you must burn wet wood, use only small amounts mixed with dry wood.
5. Decayed wood or low density wood has very little energy content or heating value, and will not burn satisfactorily for long periods of time.

An example of the energy values of some common wood fuels is given in Table 3.2  
For recommended wood sizes, refer to the specifications.

**Common Heating Values of Cordwood**

<b>Hardwoods</b>	<b>Million Btu/Cord</b>	<b>Softwoods</b>	<b>Million Btu/Cord</b>
Birch	23.6	Douglas Fir	20.6
White Oak	28.3	Hemlock	17.1
Alder	17.6	Jack Pine	18.4

**Table 3.2**

### **3.2.1 Simple Wood Moisture Test**

Add one large piece of wood to the top of an established fire. If it starts to burn on three sides within one minute, it is dry and seasoned and right for burning. If it turns black and starts to burn in three minutes, it is damp. If it turns black and does not start burning until after five minutes, it is green and wet. If it hisses at any time the wood is soaked and will not burn until excess moisture is boiled away.

### **3.3 Notes About First Firing**

Before firing ensure that the room is well ventilated.

Curing the paint is recommended to preserve the best quality finish. Heating the insert too intensely on the first fire will dull and lighten the colour on overheated areas, and cause smoke and odour to be emitted into the room. To cure the paint, the first two fires should be burned for only about twenty minutes each.

Allow the insert to get warm only, but not hot, i.e. 250° F (120° C) as measured by an insert top thermometer, then allow the insert to cool down. Light a third fire and burn it for about forty minutes to 450° F (230° C) or less. Once again cool the insert to room temperature, then operate it according to the following instructions. This extra care will result in a more durable, and uniform finish.

### **3.4 Lighting A Fire**

1. Place enough crumpled balls of newspaper or other paper into the insert to cover the bottom of the firebox.
2. Place small dry kindling on the crumpled paper.
3. Place larger dry kindling on top of the small kindling.
4. Open the draft control fully to the right (located on the right side of the faceplate, Figure 3.4)
5. Light a fire at the bottom of the crumpled paper and close the door. If the fire tends to go out, momentarily hold the door slightly ajar to fan the fire. As soon as the fire catches hold, close the door.
6. Ideally the large kindling should be burned until a thick bed of red embers is obtained. At that point, add cordwood fuel and continue to operate the draft control wide open until the fire is well established. Once the firebox is hot, the draft control can be partially closed by moving the knob to the left to adjust the intensity of the fire.

Use Table 3.4 to adjust the draft control to the desired burn rate:

#### **Draft Settings**

<b>Burn Rate</b>	<b>Draft Setting</b>
Low	Move Control left to end of travel.
Medium Low	Move Control right by 9/16" - 1" (14.3 – 25.4mm) from closed position.
Medium High	Move Control right by 7/8" - 1 3/4" (22.2 – 44.5mm) from closed position
High	Move Control to right hand end of travel.

**Table 3.4**

Closing the draft control down too soon will lower combustion efficiency, and may result in creosote build-up in the chimney (which could lead to a future chimney fire).

***CAUTION: THE ADJUSTMENT RANGE SHOULD NOT BE ALTERED FOR INCREASED FIRING FOR ANY REASON.***

HL177 - SMALL FLAME

(CUSTOMER INSTALLED, OPTIONAL)

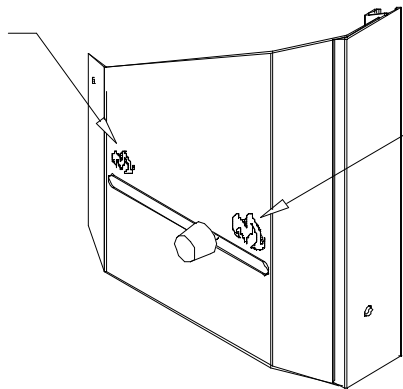

HL176 - LARGE FLAME

(CUSTOMER INSTALLED, OPTIONAL)

### **3.5 Maintaining The Fire**

Your Osburn insert will work best if a thick bed of hot embers is maintained in the bottom of the firebox, and a minimum of two large pieces of seasoned fuel are added. Combustion efficiency is largely related to establishing a hot ember bed, and hot firebox temperatures. The quicker the insert and fuel get up to operating temperature, the better. A small intense fire is preferred to a large smouldering fire, both to improve combustion efficiency and to reduce the amount of creosote emitted. The best performance will be achieved by adding relatively small amounts of fuel to a well established ember bed, and then operating with the air inlet control open long enough to achieve a hot fire. Cordwood should be placed with air in between individual pieces. Use a poker to make an air channel in the embers below the wood, this will allow air to flow under the wood for a more efficient burn.

Extended burn times can be accomplished by first operating the insert on a full load with the air inlet controls wide open. Once the fire is well established, and the moisture has been driven out of the wood, reduce the air control to a lower setting. The unit should then burn cleanly without smoldering. If the fire smolders without flame, re-establish a hotter fire before moving the air control to the lower setting. A yellow flame burning in the top of the firebox is a good indication of a clean efficiently burning fire.

Refuelling technique is important for good performance. The best efficiency and performance from your insert can be achieved by adding partial loads of fuel and allowing them to get up to operating temperature before adding additional fuel. Adding a large amount of fuel at one time will increase the time required to get the fuel up to its ignition temperature, and an extended time to reach optimal performance. When refuelling, open the air control or hold the door partially open 1" (25 mm) or less, long enough (less than 5 minutes) so that the fire has well established flames. When refuelling, care is required to ensure that fuel or embers do not fall out of the door opening. The unit will burn at about 2.0 to 2.5 lb/hr (.9 to 1.1kg/hr) at its minimum setting; approximately 20 to 25 lbs (9 to 11.3kg) of wood are required for an extended burn.

In order to achieve an optimum efficiency from your unit, we suggest that you operate it with the air control completely closed. Make sure that you have a good fire going and an adequate ember bed before you completely close the air control. Closing the air control too soon will lower combustion efficiency and may cause the fire to die out. The addition of a blower (if not already included) is highly recommended to maximize your unit's efficiency.



### **3.6 Fan Operation**

1. Allow the insert to reach operating temperature (approximately one hour), before turning on the fan, since increased airflow from the fan will remove heat and affect the start-up combustion efficiency.

***NOTE: ENSURE THE FAN CORD IS NOT IN CONTACT WITH ANY SURFACE OF THE INSERT TO PREVENT ELECTRICAL SHOCK OR FIRE DAMAGE. DO NOT RUN CORD BENEATH THE INSERT.***

2. Turn the fan on or off with the variable speed control located on the left side of the fan assembly below the bottom louvre. The switch settings are Off, High and adjustable down to Low.

## Section 4.0 Maintenance

### 4.1 Care And Cleaning

Clean the insert frequently so that soot, ash and creosote do not accumulate. Do not attempt to clean the insert, glass or door when the unit is hot. Special care must be taken with Gold surfaces in order to maintain the finish at its original brilliance. Do not use an abrasive glass cleaner which will scratch the glass or gold finish. Use only a soft clean damp cloth on the door, since some cleaners may remove the plating or paint.

#### 4.1.1 Glass Cleaning

Under normal operation the stove is designed to keep the glass clean. Glass cleaning may be required when burning damp wood and/or when burning slow fires. Generally if the glass is not staying clean then the unit is being under fired. Dirty glass may be self-cleaned by burning a hot fire (i.e. dry wood and opened draft controls) for a couple of hours. Good burning techniques will result in clean glass.

Hand clean the glass only when the fire is out and the insert is cold. A light film can usually be cleaned with paper towel and water. If heavy cleaning is required, a ceramic glass cleaner or polish is recommended, and should be rinsed off with water for best results.

### 4.2 Ash Removal

**CAUTION:** *Ashes can start fires, even after several days of inactivity. Never dispose of ashes in a combustible container. Remove ashes only when the insert and ashes are cold.*

Ashes should be removed from the insert frequently. When ashes are removed, they should be placed in a metal container with a tightly fitting lid. The closed container of ashes should be placed on a non-combustible floor or on the ground, well away from all combustible materials, pending final disposal. If the ashes are disposed of by burial in soil or otherwise locally dispersed, they should be retained in the closed container until all cinders have thoroughly cooled. Do not place other waste materials in the metal ash container.

### **4.3 Chimney Cleaning**

Regular chimney maintenance, as well as good burning practices, are required to prevent chimney fires. The chimney and the chimney connector pipe must be maintained in good condition and be kept clean for optimal safety. The chimney should be checked regularly for creosote build-up. Inspection and cleaning of the chimney can be facilitated by removing the baffle.

***CAUTION: OPERATION OF YOUR OSBURN 1800 WITHOUT THE BAFFLE MAY CAUSE UNSAFE AND HAZARDOUS TEMPERATURE CONDITIONS AND WILL VOID THE WARRANTY.***

Contact your local, municipal, state, or provincial fire authority for information on how to handle a chimney fire before there is any chance that it may happen.

#### **Creosote – Formation And Need For Removal**

When wood (especially green wood) is burned without adequate heat or air supply, it produces tar and other organic vapours (*smoke*), which combine with expelled moisture to form creosote.

The creosote vapours condense in the relatively cool chimney flue of a slow-burning fire. As a result, creosote residue accumulates on the flue lining. When ignited, this creosote makes an extremely hot fire, which could be hazardous. Check frequently for creosote build-up. In the event of a insert or chimney component failure, replace only with equipment that is equivalent to the original, available from your Osburn dealer.

Your Osburn insert has been designed to reduce the amount of creosote produced. Even so, the chimney connector pipe and chimney should be inspected at least once every two months during the heating season to determine if a creosote build-up has occurred. If creosote has accumulated, it should be removed to reduce the risk of chimney fire. Call a professional chimney sweep, or go to your local Osburn dealer and purchase a chimney brush, and have the chimney cleaned.

### **4.4 Baffle Installation and Brick Notes:**

1. Stack the baffle boards (A) on top of the vermiculite boards (B) as shown in figure 4.4a .

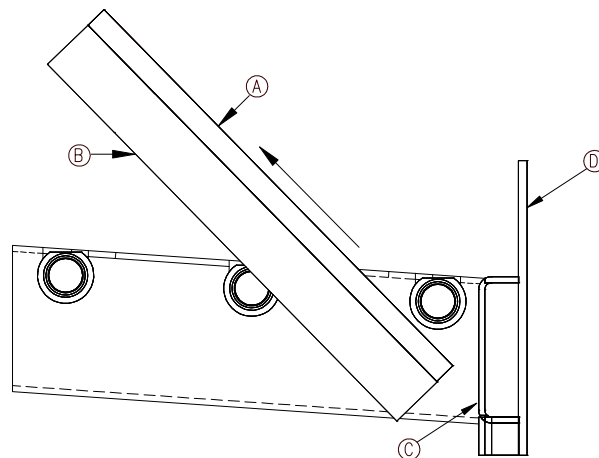

Figure 4.4a

- Put them on the horizontal air duct (C) (see figure 4.4b). Afterwards, push them towards the bottom and sides so that they rest on the back of the firebox (D) and on the side air ducts.

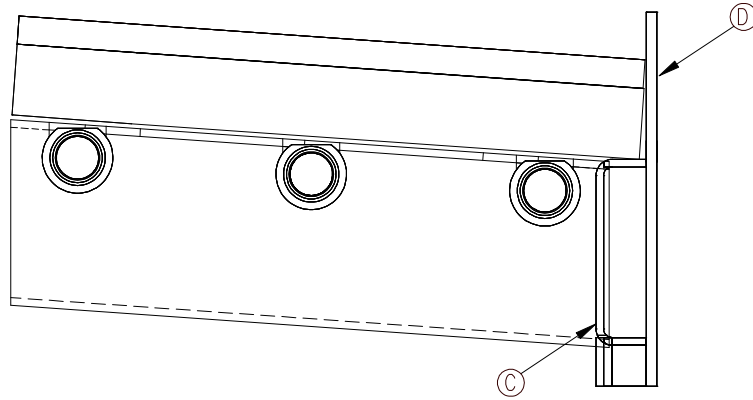

Figure 4.4b

- Install the baffle support/extension (H) ensuring that it fits between the front risers and hold it in place. Install the front secondary air tube as in figure 3.4c ensuring air holes face forward. Install the cotter pins as in fig 4.4c. Installing the front secondary air tube (E) will stabilize baffle assembly during the next step.

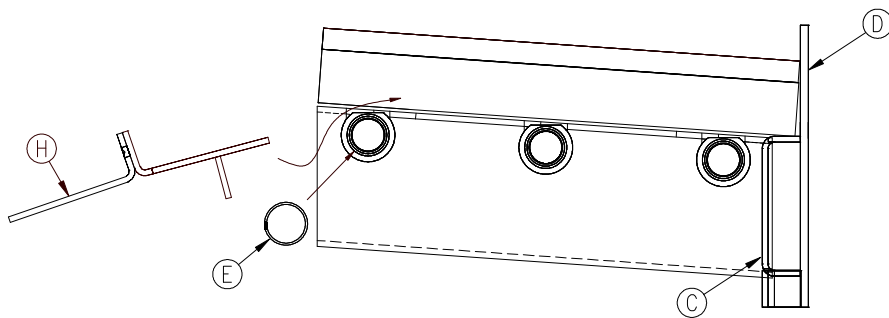

Figure 4.4c

- Install the middle (F) and rear (G) secondary air tubes ensuring air holes face forward. Install the cotter pins as in fig 4.4d.

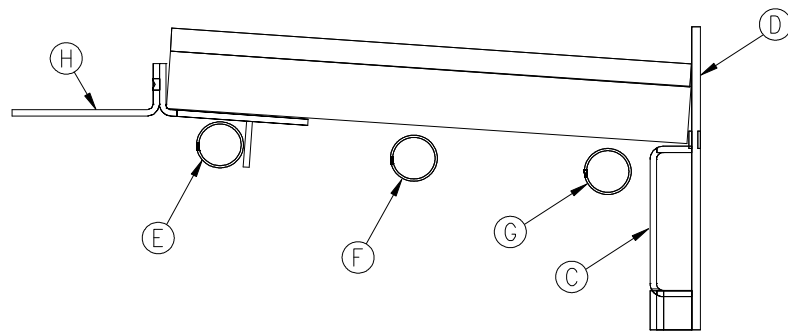
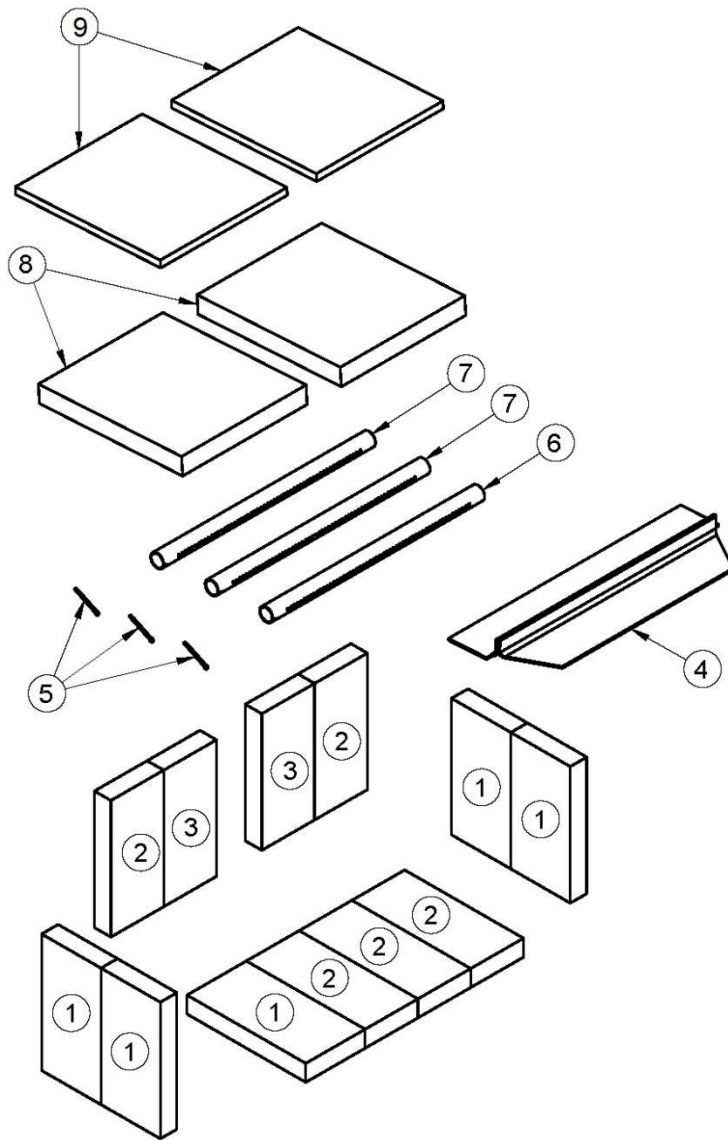

Figure 4.4d

All firebrick and duraboard baffles must be properly in place for correct burning operation. Have any damaged firebricks replaced. Check the firebricks annually for damage and replace if they are broken or damaged. See figure bellow for the firebrick layout. Install the side & back firebricks first, and then the bottom firebricks.



ITEM	PIECE #	DESCRIPTION	QTY
1	29020	4 1/2" X 9" X 1 1/4" REFRACTORY BRICK	5
2	29011	4" X 9" X 1 1/4" REFRACTORY BRICK	5
3	PL36060	3 1/2" X 9" X 1 1/4" REFRACTORY BRICK	2
4	SE37005	BAFFLE EXTENSION	1
5	30068	1/8" X 1 1/2" STAINLESS STEEL COTTER PIN	3
6	PL37031	FRONT SECONDARY AIR TUBE	1
7	PL37030	CENTRE AND REAR SECONDARY AIR TUBE	2
8	21295	1800 SERIES C-CAST BAFFLE	2
9	PL37027	BAFFLE INSULATION BLANKET	2

## **4.5 Secondary Air Tube Replacement**

(see Figure 4.5)

1. Remove cotter pin at LH end of tube.
2. Slide tube to right and lower tube end below LH plenum.
3. Slide tube to left to remove.
4. Reassemble in reverse order using a new cotter pin. The cotter pin is a hammerlock style and locks into place by hitting the head sharply with a hammer.
5. Note that any tube can be replaced without disturbing the baffle.

### **Important Notes:**

The air tubes are identified for placement as follows:

Front to back:      Tube No. 1   56 Holes   of   .140" diameter  
                              Tube No. 2   56 Holes   of   .125" diameter  
                              Tube No. 3   56 Holes   of   .125" diameter

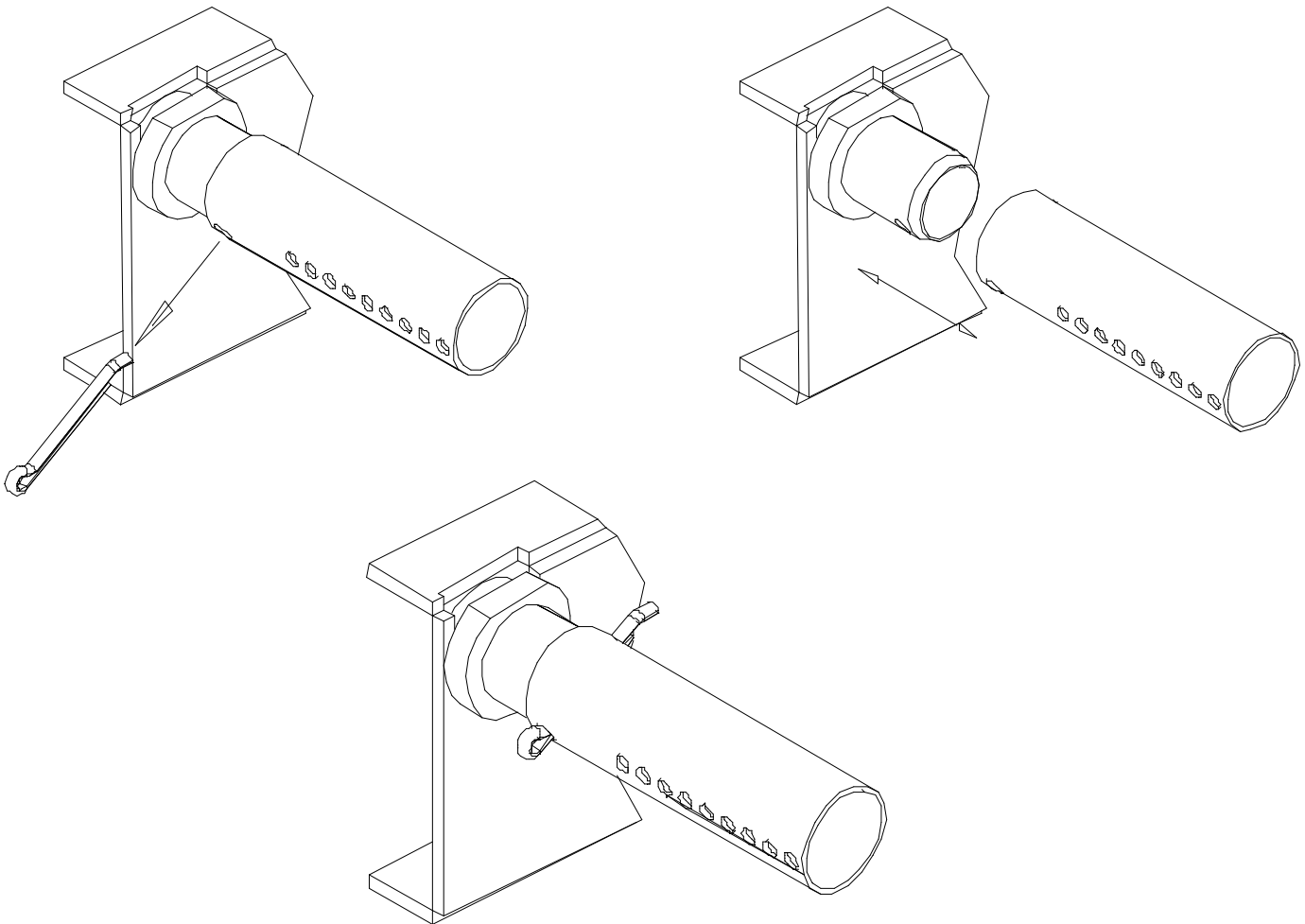

**Figure 4.5 – Secondary Air Tube replacement**

## **4.6 Fan Maintenance & Care**

Clean the fan air inlet louvres and squirrel cage impeller regularly. The fan should be kept clean and dust free. Life of the fan will be shortened if operated in a dust filled environment, or if the fan is overheated by restricting air supply. Stalling the rotor, or over firing the insert with the fan turned off will also damage the fan. The fan must not be overheated. Do not disassemble the fan. ***"ALTERING OR TAMPERING WITH THE FAN WILL VOID THE WARRANTY"***.

## **Section 5.0 Troubleshooting**

<b>Symptom</b>	<b>Possible Cause</b>	<b>Corrective Action</b>
<b>I Smoke in room</b>	<ol style="list-style-type: none"><li>1. Down draft</li><li>2. Chimney blocked</li><li>3. Chimney damper shut</li><li>4. Baffle out of position</li><li>5. New paint is curing</li></ol>	<ol style="list-style-type: none"><li>1. Upgrade chimney</li><li>2. Clean chimney</li><li>3. Open or remove damper</li><li>4. Correctly position baffle</li><li>5. Refer to instructions</li></ol>
<b>II Wood burns poorly or is slow to start or no heat</b>	<ol style="list-style-type: none"><li>1. Low draw</li><li>2. Wet or decayed wood</li><li>3. Blocked intake air</li></ol>	<ol style="list-style-type: none"><li>1. Upgrade chimney</li><li>2. Use proper fuel</li><li>3. Check intake air supply by removing fan from insert and opening a window</li></ol>
<b>III Dirty glass</b>	<ol style="list-style-type: none"><li>1. Insert is being under fired</li></ol>	<ol style="list-style-type: none"><li>1. Refer to instructions</li></ol>
<b>IV Wood burns too fast</b>	<ol style="list-style-type: none"><li>1. Too much draft in chimney</li></ol>	<ol style="list-style-type: none"><li>1. Consult a qualified technician.</li></ol>

# Section 6.0 General information on 1800 insert (OB01801)

## 6.1 Appliance performance<sup>(1)</sup>

Fuel type	Dry cordwood	
Recommended heating area <sup>[*]</sup>	500 to 1,800 ft <sup>2</sup> (46 to 167 m <sup>2</sup> )	
Firebox volume	1.8 ft <sup>3</sup> (0.051 m <sup>3</sup> )	
Maximum burn time <sup>[*]</sup>	6 h	
Maximum heat output <sup>(2)</sup> (dry cordwood)	65,000 BTU/h (19.0 kW)	
Overall heat output rate (min. to max.) <sup>(2)(3)</sup>	9,700 BTU/h to 36,300 BTU/h (2.8 kW to 10.6 kW)	
Average overall efficiency <sup>(3)</sup> - EPA Cribs / Douglas Fir	66.0% (HHV <sup>(4)</sup> )	71.0% (LHV <sup>(5)</sup> )
Average overall efficiency <sup>(3)</sup> - Dry cordwood	To come (HHV <sup>(4)</sup> )	To come (LHV <sup>(5)</sup> )
Optimum efficiency <sup>(2)(6)</sup>	75.0%	
Average particulate emissions rate <sup>(7)</sup>	2.8 g/h (EPA / CSA B415.1-10)	
Average CO <sup>(8)</sup>	To come	

[\*] Recommended heating area and maximum burn time may vary subject to location in home, chimney draft, heat loss factors, climate, fuel type and other variables. The recommended heated area for a given appliance is defined by the manufacturer as its capacity to maintain a minimum acceptable temperature in the designated area in case of a power failure.

- (1) Values are as measured per test method, except for the recommended heating area, firebox volume, maximum burn time and maximum heat output.
- (2) The maximum heat output (dry cordwood) is based on a loading density varying between 15 lb/ft<sup>3</sup> and 20 lb/ft<sup>3</sup>. Other performances are based on a fuel load prescribed by the standard. The specified loading density varies between 7 lb/ft<sup>3</sup> and 12 lb/ft<sup>3</sup>. The moisture content is between 19% and 25%.
- (3) As measured per CSA B415.1-10 stack loss method.
- (4) Higher Heating Value of the fuel.
- (5) Lower Heating Value of the fuel.
- (6) Optimum overall efficiency at a specific burn rate (LHV).
- (7) This appliance is officially tested and certified by an independent agency.
- (8) Carbon monoxide.



## **6.2 General Features**

Maximum log length	18 in (457 mm) east-west*
Flue outlet diameter	6 in (152 mm)
Recommended connector pipe diameter	6 in (152 mm)
Type of chimney	ULC-S635, CAN/ULC-S640, UL1777
Baffle material	C-Cast
Approved for alcove installation	Not approved
Approved for mobile home installation <sup>‡</sup>	Not approved
Shipping weight (without option)	307 lb (139 kg)
Appliance weight (without option)	255 lb (116 kg)
Type of door	Single, glass with steel frame
Type of glass	Ceramic glass
Blower	Included (up to 90 CFM)
Particulate emission standard	EPA / CSA B415.1-10
USA standard (safety)	UL 1482
Canadian standard (safety)	ULC S628

\*\* *East-west: through the door you see the longitudinal sides of the logs; north-south: through the door you see the tips of the logs.*

<sup>‡</sup> *Mobile home (Canada) or manufactured home (USA): The US department of Housing and Urban Development describes “manufactured homes” better known as “mobile homes” as followed; buildings built on fixed wheels and those transported on temporary wheels/axles and set on a permanent foundation. In Canada, a mobile home is a dwelling for which the manufacture and assembly of each component is completed or substantially completed prior to being moved to a site for installation on a foundation and connection to service facilities and which conforms to the CAN/CSA-Z240 MH standard.*

# OSBURN LIMITED LIFETIME WARRANTY

The warranty of the manufacturer extends only to the original retail purchaser and is not transferable. This warranty covers brand new products only, which have not been altered, modified nor repaired since shipment from factory. Proof of purchase (dated bill of sale), model name and serial number must be supplied when making any warranty claim to your OSBURN dealer.

**This warranty applies to normal residential use only. Damages caused by misuse, abuse, improper installation, lack of maintenance, over firing, negligence or accident during transportation, power failures, downdrafts, venting problems or under-estimated heating area are not covered by this warranty. The recommended heated area for a given appliance is defined by the manufacturer as its capacity to maintain a minimum acceptable temperature in the designated area in case of a power failure.**

This warranty does not cover any scratch, corrosion, distortion, or discoloration. Any defect or damage caused by the use of unauthorized or other than original parts voids this warranty. An authorized qualified technician must perform the installation in accordance with the instructions supplied with this product and all local and national building codes. Any service call related to an improper installation is not covered by this warranty.

The manufacturer may require that defective products be returned or that digital pictures be provided to support the claim. Returned products are to be shipped prepaid to the manufacturer for investigation. Transportation fees to ship the product back to the purchaser will be paid by the manufacturer. Repair work covered by the warranty, executed at the purchaser's domicile by an authorized qualified technician requires the prior approval of the manufacturer. All parts and labour costs covered by this warranty are limited according to the table below.

The manufacturer, at its discretion, may decide to repair or replace any part or unit after inspection and investigation of the defect. The manufacturer may, at its discretion, fully discharge all obligations with respect to this warranty by refunding the wholesale price of any warranted but defective parts. The manufacturer shall, in no event, be responsible for any uncommon, indirect, consequential damages of any nature, which are in excess of the original purchase price of the product. A one-time replacement limit applies to all parts benefiting from lifetime coverage. This warranty applies to products purchased after June 1<sup>st</sup>, 2015.

DESCRIPTION	WARRANTY APPLICATION*	
	PARTS	LABOUR
Combustion chamber (welds only) and cast iron door frame.	Lifetime	5 years
Ceramic glass (thermal breakage only**), plating (manufacturing defect**) and convector air-mate.	Lifetime	N/A
Surrounds, heat shields, ash drawer, steel legs, pedestal, trims (aluminum extrusions), C-Cast baffle**, vermiculite baffle**, secondary air tubes**, removable stainless steel combustion chamber deflectors and supports.	7 years	N/A
Handle assembly, glass retainers and air control mechanism.	5 years	3 years
Removable carbon steel combustion chamber components.	5 years	N/A
Standard and optional blower, heat sensors, switches, rheostat, wiring and electronics.	2 years	1 year
Paint (peeling**), gaskets, insulation, ceramic fiber blankets, firebricks and other options.	1 year	N/A
All parts replaced under the warranty.	90 days	N/A

*\*Subject to limitations above. \*\*Picture required.*

Labour cost and repair work to the account of the manufacturer are based on a predetermined rate schedule and must not exceed the wholesale price of the replacement part.

Shall your unit or a components be defective, contact immediately your **OSBURN** dealer. To accelerate processing of your warranty claim, make sure to have on hand the following information when calling:

- Your name, address and telephone number;
- Bill of sale and dealer's name;
- Installation configuration;
- Serial number and model name as indicated on the nameplate fixed to the back of your unit;
- Nature of the defect and any relevant information.

**Before shipping your unit or defective component to our plant, you must obtain an Authorization Number from your OSBURN dealer. Any merchandise shipped to our plant without authorization will be refused automatically and returned to sender.**